

本目录册机器图片、样品图片、技术参数仅供参考，最终解释权归本公司所有。  
All the machine photos, sample photos and technical parameters on catalog just as reference for you.  
The final interpretation belong to us.

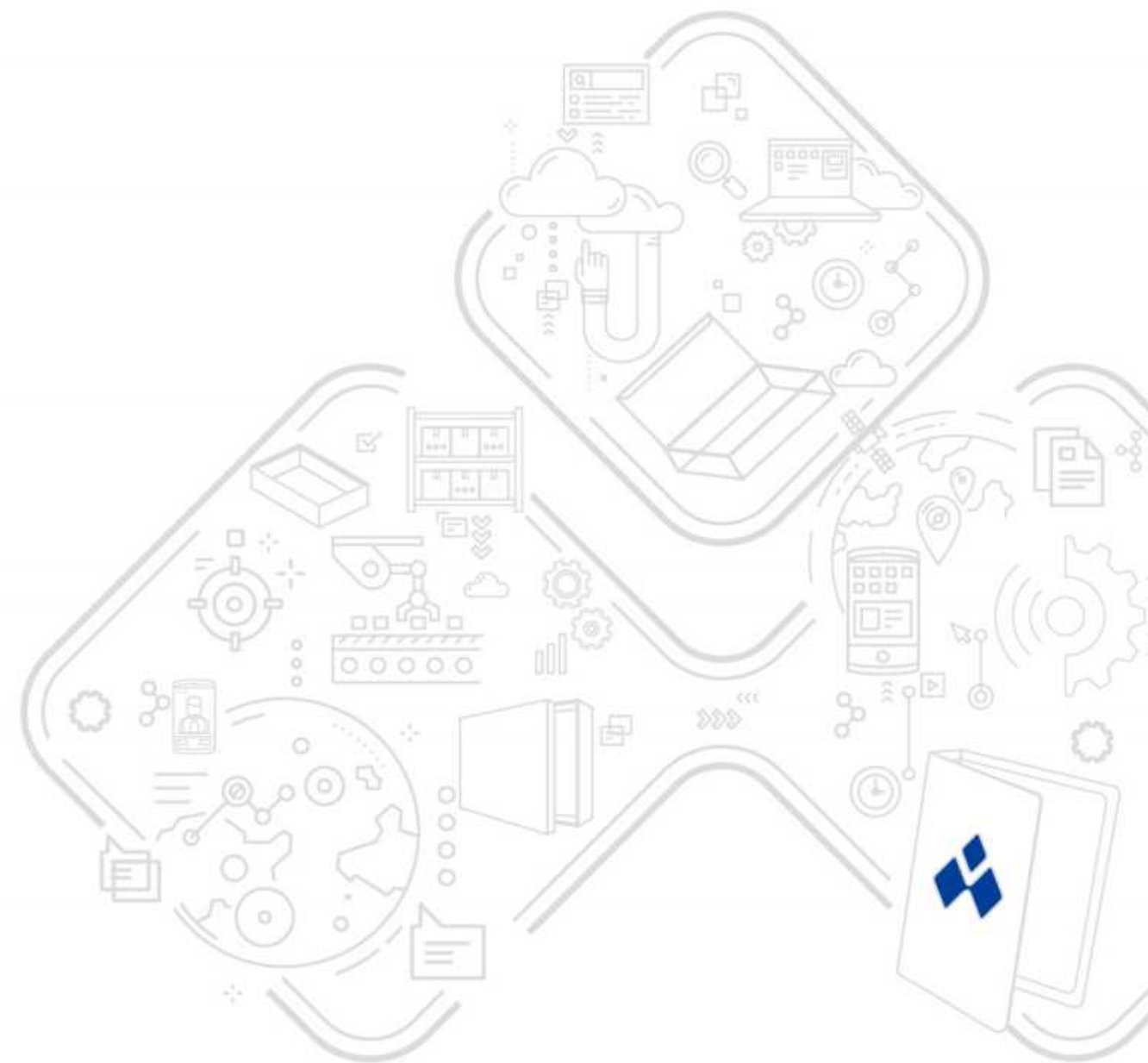

**浙江正润机械有限公司**  
ZHEJIANG ZHENGRUN MACHINERY CO.,LTD.

总部地址:  
浙江省平阳县滨海新区平海大道东段23号  
Add: No. 23, Pinghai Eastern Section Of Pinghai  
Avenue, Binhai New Area, Pingyang County  
Zhejiang Province, China.

总机 (Tel): +86-(0)577-58118888  
传真 (Fax): +86-(0)577-58118666  
电子邮箱 (E-mail): sales@zheng-run.cn

销售热线 (Sales Hotline): 400-1111-058  
售后服务 (After-sale): +86-577-58122666

Export:  
Michael Cai  
+86 (0) 57758118668  
sales@zheng-run.cn

Eason  
+86 (0) 57758118671  
Market@zheng-run.cn

 访问官网了解更多  
www.zheng-run.cn



正润官方小程序

Zhengrun -  
Leading The New Direction Of  
Intelligent Production

正润-引领智能生产新方向

二十年如一

## 专注于包装机械生产制造

Twenty Years As One Focus On Packaging Machinery Manufacturing

### Introduction

Zhejiang Zhengrun Machinery Co., Ltd., established in 1997, is the first domestic brand to start the business of packaging equipment production. The Company is mainly engaged in the R&D, design, production and sales of the rigid box machinery and case maker machine. It's rated as a National High-Tech Enterprise, National Intellectual Property Advantage Enterprise, Provincial enterprise R&D center, Wenzhou Civilized Unit, Pingyang County New Age Civilization Practice Enterprise Culture Demonstration Base.

The company has the modern standard factory buildings covering 66,000 square meters, as well as a highly professional R&D and production team and the world's leading super-large production and processing center. Zhengrun's packaging equipment can be applied to the gift box packaging of many brands in multiple fields, such as fields of

electronics, cosmetics, jewelry, wine, clothing and shoes, food and drink (like moon cakes and tea), desk calendars, and notebooks. The company has the right to import and export, and has gained the certification of ISO9001 quality management system with all products gained the European CE product certification. The products and services now cover more than 80 countries and regions.

Since its inception, the Company always adheres to the business development concept of considering that "Quality Builds Zhengrun Brand". The Company passes on the artisan spirit, pursues higher quality and aims to establish a stronger brand, so as to become the world's representative "Made in China" brand in printing and packaging industry!

### 概况

浙江正润机械有限公司成立于1997年，是国内最早开启包装设备事业的民族品牌，专业从事天地盖制盒设备和封面机设备的研发、设计、生产、销售。被评为国家高新技术企业、国家知识产权优势企业、省级企业研发中心、温州市文明单位、平阳县新时代文明实践企业文化示范基地。

公司拥有66000平方米的现代化标准厂房，以及高度专业的研发生产团队和国际领先的超大型生产加工中心设备。正润包装设备涉及许多领域，比如电子设备、化妆品、首饰、酒业、服装鞋业、月饼茶叶、台历笔记本等，

为诸多知名品牌供应礼盒、彩盒包装。公司拥有自营进出口权，全面通过ISO9001质量管理体系认证，所有产品已通过欧洲CE产品认证，产品与服务覆盖全球80多个国家与地区。

自成立以来，正润机械始终秉承“品质铸造 正润品牌”的企业发展理念，传承工匠精神，追求更高品质、树立更强品牌，致力于成为影响世界印包行业、具有传承价值的“中国制造”代表品牌！



# 01

## About Us 关于我们

• 公司简介 Company Profile	1-2
• 历程与发展 History	59-64
• 售后服务 Sales Service	65-66
• 中德介绍 Zhongde Introduction	67-70

# 02

## Automatic Rigid Box Maker 全自动纸盒成型机

• RB380S 全自动纸盒成型机 Automatic Rigid Box Maker	5-8
• RB380 (双工位 Double Station) 全自动纸盒成型机 Automatic Rigid Box Maker	9-10
• RB380 A/B (智能机 Intelligent Type) 全自动纸盒成型机 Automatic Rigid Box Maker	11-14
• RB185 RB185A/RB185B (智能机 Intelligent Type) 全自动纸盒成型机 Automatic Rigid Box Maker	15-18
• RB240 全自动纸盒成型机 Automatic rigid box maker	19-22
• RB6040/6040A 全自动纸盒成型机 Automatic Rigid Box Maker	23-26
• JH3816 全自动酒盒成型机 Wine Box Making Machine	27-30

# 03

## Automatic Case Maker 全自动封面机概况

• CM450A/540A/600A 全自动封面机 Automatic Case Maker	33-34
• CM540S 全自动裱内衬机 Automatic Lining Machine	35-36
• CMD540 全自动封面一体机 Fully Automatic Case Maker Line	39-40
• CB540 机械手两用定位机 Robot Positioning Machine	41-42
• JB450/540/650/800 酒包定位机 Wine Bag Positioning Machine	43-44
• CB450A/540A 全自动视觉封面机 Automatic Case Maker (Visual Positioning)	45-46

# 04

## Supporting Machine 配套机器

• KL1300A(单机) KL1300AS(纵横线) KL1300ASB(带飞达) KL1300ASD(带飞达带自动收料) 全自动纵横纸板分切机 Cardboard Cutter	47-50
• KX650SD 全自动开板开槽一体机 Cardboard Cutting and slotting machine	52
• CW380 全自动围框机 Fully automatic framing machine	53
• ATJ600/380 自动贴角机 Automatic Corner Pasting Machine	54
• ZX450 中心条分切机 Spine Cutter	55
• QJ80 切角机 Angle Cutter	55
• ZR9060 磁铁机 Magnet (Steel Disc) Pasting Machine	56
• FB650 全自动书型盒组装机 Automatic Book Style Box Assembling Machine	56
• KC1000 全自动开槽机 Automatic Groover	57
• ATJ380 自动贴角机 Automatic Corner Pasting Machine	57
• BF450 气动纸盒成型机 Pneumatic Box Wrapper	58
• ZHYP600 全自动压泡机 Box Pressing Machine	58

# Automatic Rigid Box Maker

## 全自动纸盒成型机



### 用途

全自动天地盖制盒机是生产制作高档精品天地盖纸盒的最佳设备,它设计合理、性能可靠、达到世界同等技术水平。采用 PLC 控制、光电跟踪定位、液压纠偏、触摸屏人机界面,实现自动送面纸、面纸上胶、纸板自动输送、纸板贴角、纠偏定位贴合、纸盒包边成型等动作一次性完成,有效代替人工生产,大大提高生产效率与纸盒成品质量。可适用于手机盒、鞋盒、化妆品盒、衬衫盒、月饼盒、酒盒、香烟盒、茶叶盒等高档纸盒包装。

### USE

Automatic Rigid Box marker is a good equipment for making high-grade boxes which is featured by fine design, reliable performances and international advanced technologies. It employs PLC, photoelectric detector system, hydraulic rectifying system, HMI to automatically finish feeding and gluing paper, conveying cardboard, forming and gluing four angles of cardboard, positioning and forming box in one time, instead of manual production, greatly improving the production efficiency and quality of rigid boxes. It is applicable to make high-grade boxes for cell phones, shoes, cosmetics, shirts, moon cakes, liquors, cigarettes, teas, etc.

### 技术参数图列

Technical Parameter Diagram

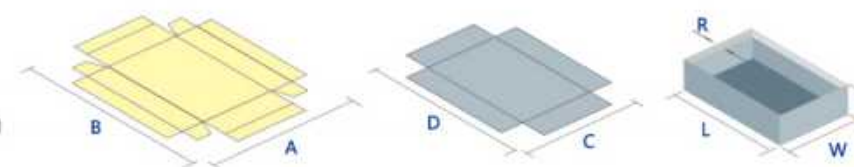

### 备注 Remark

1. 盒子的最大和最小尺寸, 取决于面纸的最大和最小尺寸以及面纸的质量。
  2. 盒子的尺寸大小会影响到机器的速度。
  3. 厂家不提供空气压缩机。
- 1.The Max. and Min. sizes of the boxes are subjected to the sizes and quality of the paper.  
2.The speed of the machine depends on the sizes of the boxes.  
3.We don't provide air compressor.

### 各参数之间的相应关系

The Corresponding Relationship Between The Parameters

$$W+2H-4T \leq C(\text{Max})$$

$$A(\text{Min}) \leq W+2H+2T+2R \leq A(\text{Max})$$

$$L+2H-4T \leq D(\text{Max})$$

$$B(\text{Min}) \leq L+2H+2T+2R \leq B(\text{Max})$$

### 面纸类型

Paper Wrap Type



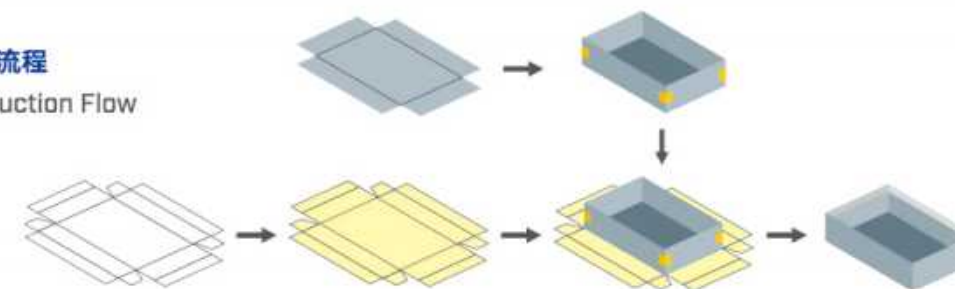

### 生产流程

Production Flow



# RB380S

## 全自动纸盒成型机

-  Automatic Rigid Box Maker
-  Maquina Automática de Caja Rígida
-  Ligne de machines à boîte

### 功能特点 Functional Features



单联、双联双模式，一体成型

Single And Twin Mode, One Piece Forming  
suitable for produce the top & bottom  
box(telescope box) at the same time



# RB380S

## 全自动纸盒成型机

-  Automatic Rigid Box Maker
-  Maquina Automática de Caja Rigida
-  Ligne de machines à boîte

### 技术参数 Technical Parameters

型号	Model	双出盒模式	单出盒模式
纸盒尺寸	Box Size(WxL)	Min.30×60mm Max.240×380mm	Min.30×60mm Max.260×380mm
面纸尺寸	Paper Size(AxB)	Min.70×120mm Max.350×630mm	Min.70×120mm Max.480×630mm
纸盒高度	Box Height(H)	10-140mm	10-140mm
折边尺寸(R)	Turn In Depth(R)	10-100mm	10-100mm
纸板厚度	Cardboard Thickness(T)	0.8~3mm	0.8~3mm
面纸厚度	Paper Thickness	100-400g/m <sup>2</sup>	100-400g/m <sup>2</sup>
面纸堆放高度	Paper Stacking Height	750mm	750mm
定位精度	Precision	±0.10mm	±0.10mm
生产速度	Speed	≤56pcs/min	≤30pcs/min
电机功率	Motor Power	28kw/380v 3phase	28kw/380v 3phase
电热功率	Electric Heating Power	12kw	12kw
气源要求	Air Supply	70L/min 0.6Mpa	50L/min 0.6Mpa
整机尺寸	Machine Dimension	L7700×W7100×H 3300mm	L7700×W7100×H 3300mm
机器重量	Machine Weight	6000kg	6000kg

### 产品优势 Product Advantage

**1 Double Feeder Paper Feeding System With Several Patented Technologies**  
拥有多个专利技术的双飞达给纸系统

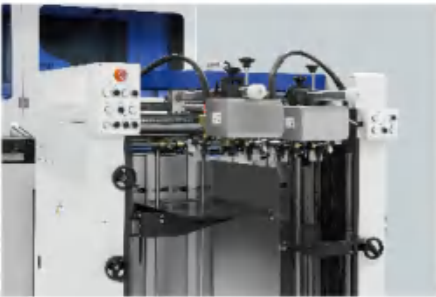

Double Feta feeder for more stable and reliable tissues

双飞达送面纸,更稳定更可靠

**2 Duplex Image Positioning System**  
双工位影像定位系统



Original imported robot, double-station suction cassette, fast and efficient

先进稳定的机械手送盒系统,双工位吸纸盒、快速高效

**3 Servo Controlled Forming Structure**  
伺服控制成型结构



The servo control molding pressure is large, which can be comparable to the bubble pressing effect.

伺服控制成型,成型压力大,可堪比压泡效果。

**4 Dual Channel, Dual Corner Mounting**  
双通道、双贴角

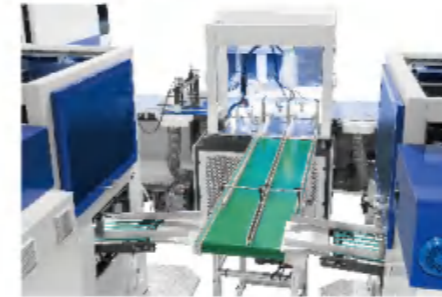

Dual access, dual corner fitting for efficient production

双通道、双贴角,满足高效率生产需求

**5 Advanced Linear Motor Drive**  
先进的直线电机驱动

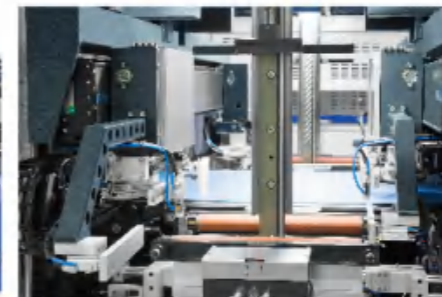

The box feeding system adopts the most advanced linear motor driving method, with high efficiency, stability and no noise.

送盒系统采用目前最先进的直线电机驱动方式,具有高效、稳定、无噪音的特点

**6 Automatic Centralized Fuel Supply System**  
自动集中供油系统

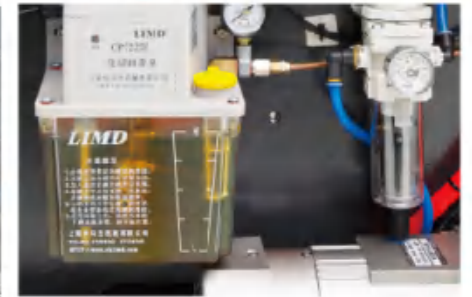

The regular and quantitative centralized oil supply system can fully guarantee the lubrication of the main parts and effectively ensure the stable operation of the machine.

定时定量集中供油系统能全面保证主要部位的润滑,有效保证机器的稳定运行。

# RB380 | (双工位 Double Station)

## 全自动纸盒成型机

-  Automatic Rigid Box Maker
-  Maquina Automática de Caja Rígida
-  Ligne de machines à boîte



智能化  
Intelligent



数字化  
Digital





多元化  
Diversified



人性化  
User-friendly

# RB380A/B | (智能机 Intelligent Type)

## 全自动纸盒成型机

-  Automatic Rigid Box Maker
-  Maquina Automática de Caja Rigida
-  Ligne de machines à boîte



智能化  
Intelligent



数字化  
Digital



多元化  
Diversified



人性化  
User-friendly



# RB380 | (双工位 Double Station)

# RB380A/B | (智能机 Intelligent Type)

## 全自动纸盒成型机



Automatic Rigid Box Maker



Maquina Automática de Caja Rígida



Ligne de machines à boîte

### 技术参数 Technical Parameters

型号	Model	RB380 (双工位 Double Station)	RB380A/B (智能机 Intelligent Type)
纸盒尺寸	Box Size[WxL]	Min. 50×60mm Max. 260×380mm	Min. 50×60mm Max. 260×380mm
面纸尺寸	Paper Size[AxB]	Min. 70×120mm Max. 480×630mm	Min. 70×120mm Max. 480×630mm
纸盒高度	Box Height[H]	10-140mm	10-140mm
折边尺寸	Turn In Depth[R]	10-100mm	10-100mm
纸板厚度	Cardboard Thickness[T]	0.8-3mm	0.8-3mm
面纸厚度	Paper Thickness	100-400g/m <sup>2</sup>	100-400g/m <sup>2</sup>
面纸堆放高度	Paper Stacking Height	650mm	450/650mm
定位精度	Precision	±0.1mm	±0.1mm
生产速度	Speed	< 50pcs/min	≤30pcs/min
电机功率	Motor Power	28kw/380v 3phase	19kw/380v 3phase
电热功率	Electric Heating Power	12kw	12kw
气源要求	Air Supply	60L/min 0.6Mpa	40L/min 0.6Mpa
整机尺寸	Machine Dimension	L6800×W5700×H3300mm	L6800×W4500×H3300mm
机器重量	Machine Weight	5500kg	4800kg

### 产品优势 Product Advantage

#### 1 Camera Positioning System

影像定位系统



China's first three camera positioning system and independent box positioning system, combined with the robot to take the box, is currently advanced and high-precision positioning technology.

国内首创三视觉影像系统及纸盒独立定位系统,配合机械手取盒,是目前先进、高精度的定位技术。

#### 2 Quick Digital Adjustment

数字化快速调节



The newly designed servo and pneumatic control structure completes the box forming and wrapping, and realizes rapid digital adjustment.

全新设计的伺服与气动控制结构完成纸盒贴角及成型,实现数字化快速调节。

#### 3 Servo-controlled Paper Feeder

伺服控制成型结构



The servo control molding pressure is large, which can be comparable to the bubble pressing effect.

伺服控制成型,成型压力大,可堪比压泡效果。

#### 4 Servo-controlled Paper Feeder

全新伺服控制的后吸式面纸飞达



The newly designed servo-controlled paper feeder adopts the rear suction type to feed paper, effectively preventing double sheets of paper, and stable operation

全新设计的伺服控制面纸飞达,采用后吸前推送纸,有效防止双张,运行稳定。

#### 5 Non-stop Stack Conversion Device

不停机叠放转换装置



The non-stop stacking conversion device can realize non-stop transportation and ensure the high-speed operation of the machine.

不停机叠放转换装置,可以实现不停机输送,保证机器高速运转。

#### 6 Automatic Centralized Lubrication System

自动集中供油系统





The regular and quantitative centralized oil supply system can fully guarantee the lubrication of the main parts and effectively ensure the stable operation of the machine.

定时定量集中供油系统能全面保证主要部位的润滑,有效保证机器的稳定运行。

# RB185

## RB185A/B | (智能机 Intelligent Type)

### 全自动纸盒成型机

-  Automatic Rigid Box Maker
-  Maquina Automática de Caja Rigida
-  Ligne de machines à boîte

(图为RB185反机) [The picture shows the RB185 anti-machine]





更智能的机器 / 数字化调节方式  
满足多样化的纸盒

More Intelligent / Digital Adjustment  
Apply To Various Boxes

# RB185

## RB185A/B | (智能机 Intelligent Type)

### 全自动纸盒成型机

-  Automatic Rigid Box Maker
-  Maquina Automática de Caja Rígida
-  Ligne de machines à boîte

#### 技术参数 Technical Parameters

型号	Model	RB185	RB185A	RB185B (智能机 Intelligent type)
纸盒尺寸	Box Size(WxL)	Min. 50×100mm Max. 400×600mm	Min. 50×100mm Max. 400×600mm	Min. 50×100mm Max. 400×600mm
面纸尺寸	Paper Size(AxB)	Min. 95×180mm Max. 610×850mm	Min. 95×180mm Max. 610×850mm	Min. 95×180mm Max. 610×850mm
纸盒高度	Box Height(H)	10-185mm	10-140mm	10-140mm
折边尺寸	Turn In Depth(R)	10-100mm	10-100mm	10-100mm
纸板厚度	Cardboard Thickness(T)	0.8-3mm	0.8-3mm	0.8-3mm
面纸厚度	Paper Thickness	100-400g/m <sup>2</sup>	100-400g/m <sup>2</sup>	100-400g/m <sup>2</sup>
定位精度	Precision	±0.1mm	±0.1mm	±0.1mm
生产速度	Speed	≤30pcs/min	≤30pcs/min	≤30pcs/min
电机功率	Motor Power	20kw/380v 3phase	20kw/380v 3phase	20kw/380v 3phase
电热功率	Electric Heating Power	12kw	12kw	12kw
气源要求	Air Supply	50L/min 0.6Mpa	50L/min 0.6Mpa	50L/min 0.6Mpa
整机尺寸	Machine Dimension	L7000×W5000×H3600mm	L7000×W5000×H3300mm	L7000×W5000×H3600mm
机器重量	Machine Weight	6800kg	6800kg	6800kg
面纸类型	Paper Wrap Type	1/2/3	1/2/3	1/2/3

#### 产品优势 Product Advantage

##### 1 Camera Positioning System 影像定位系统



Three camera positioning and mechanical arm clamping box to achieve high-precision positioning.

三视觉影像定位和机械臂夹盒,实现高精度定位。

##### 2 Digital Adjustment Of Sizes 数字化快速调节尺寸



Adopt new design of servo and pneumatic structure to wrap the box, fast digital adjustment of sizes.

全新设计的伺服与气动控制结构完成纸盒成型,数字化快速调节尺寸。

##### 3 Servo Controlled Paper Feeder 全新伺服控制的后吸式面纸飞达



New designed servo controlled paper feeder adopts post-sucking pre-pushing type to convey paper which efficiently avoids two pieces of papers entering into the machine.

全新设计的伺服控制面纸飞达,采用后吸前推送纸,有效防止双张,运行稳定。

##### 4 Line-touch Designed Copper Scraper 线接触式铜刮刀



The copper scraper cooperates with the glue roller by line-touch design which makes the scraper more durable.

铜刮刀与胶辊采用线接触式设计,使铜刮刀能更经久耐用。

##### 5 Automatic Centralized Lubrication System 自动集中供油系统

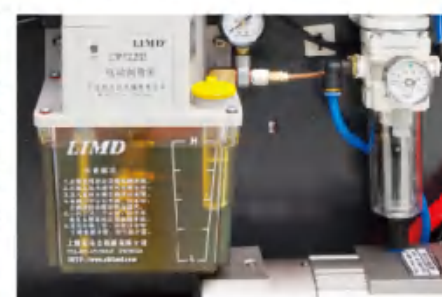

The regular and quantitative centralized oil supply system can fully guarantee the lubrication of the main parts and effectively ensure the stable operation of the machine.

定时定量集中供油系统能全面保证主要部位的润滑,有效保证机器的稳定运行。

##### 6 Glue Viscosity Control Configuration 胶水粘度控制配置





Auto glue viscosity meter efficiently adjusts the glue stickiness which ensures the quality of finished products.

自动胶水粘度控制装置能有效控制胶水的粘度,保证胶水的粘性与成品的质量。

# RB240

## 全自动纸盒成型机

-  Automatic rigid box maker
-  Maquina Automática de Caja Rigida
-  Emballeuse automatique



**更节能 / 低噪音 / 更经济 / 更精巧**

More energy-efficient / Low noise  
More economical / More sophisticated



# RB240

## 全自动纸盒成型机

-  Automatic rigid box maker
-  Maquina Automática de Caja Rigida
-  Emballeuse automatique

### 技术参数 Technical Parameters

型号	Model	RB240
纸盒尺寸	Box Size(WxL)	Min. 45×45mm Max. 160×240mm
面纸尺寸	Paper Size(AxB)	Min. 80×110mm Max. 305×450mm
纸盒高度	Box Height(H)	12-80mm
折边尺寸	Turn In Depth(R)	10-20mm
纸板厚度	Cardboard Thickness(T)	0.8-3mm
面纸厚度	Paper Thickness	80-300g/m
定位精度	Precision	±0.2mm
生产速度	Speed	<35pcs/min
电机功率	Motor Power	8kw/380v 3phase
电热功率	Electric Heating Power	7kw
气源要求	Air Supply	20L/min 0.6Mpa
整机尺寸	Machine Dimension	L4300×W3900×H2600mm
机器重量	Machine Weight	4000kg
面纸类型	Paper Wrap Type	1

### 产品优势 Product Advantage

#### 1 Chromed glue roll 镀铬胶辊上胶



New Processed chromed glue roller makes the gluing evenly and thinly.

全新工艺的镀铬胶辊，上胶均匀轻薄，经久耐用。

#### 2 Paste four corners in one time 一步完成贴四角



Use environment-friendly tape to paste four corners, forming the box in one time with good appearance.

采用环保贴角带对纸盒四角贴角，一次成型，成品美观平整

#### 3 HD camera positioning 高清摄像头定位



HD camera positioning technology makes the operation easy and accurate.

高清摄像头定位技术，操作直观、精确无误

#### 4 Mechanical box gripper 机械臂夹盒成型



Adopt mechanical gripper to deliver the box. Its adjustment is simple and fast.

机械臂夹盒，调节简单快速

#### 5 All icons control panel 全图标式控制面板





Friendly-designed all icons control panel, easy to understand and operate.

人性化设计的全图标式控制面板，简单形象易懂，方便操作

# RB6040

# RB6040A

## 全自动纸盒成型机

-  Automatic Rigid Box Maker
-  Maquina Automática de Caja Rigida
-  Ligne de machines à boîte

(图为RB6040反机) (The picture shows the RB6040 anti-machine)

全机械式设计，稳定可靠 / 欧洲技术，  
中国制造，完美的结合 用户好评机型，值得信赖的品质

Integrally mechanical design, reliable and stable.  
European technology, Chinese manufacture,  
perfect combined.Well-accepted, quality-trustworthy.



# RB6040

# RB6040A

## 全自动纸盒成型机

 Automatic Rigid Box Maker

 Maquina Automática de Caja Rigida

 Ligne de machines à boîte

### 技术参数 Technical Parameters

型号	Model	RB6040	RB6040A
纸盒尺寸	Box Size(WxL)	Min. 50×100mm Max. 400×600mm	Min. 50×100mm Max. 400×600mm
面纸尺寸	Paper Size(AxB)	Min. 95×180mm Max. 610×850mm	Min. 95×180mm Max. 610×850mm
纸盒高度	Box Height(H)	12-150mm	12-150mm
折边尺寸	Turn In Depth(R)	10-35mm	10-80mm
纸板厚度	Cardboard Thickness(T)	0.8-3mm	0.8-3mm
面纸厚度	Paper Thickness	100-400g/m <sup>2</sup>	100-400g/m <sup>2</sup>
定位精度	Precision	±0.3mm	±0.3mm
生产速度	Speed	≤35pcs/min	≤35pcs/min
电机功率	Motor Power	10kw/380v 3phase	10kw/380v 3phase
电热功率	Electric Heating Power	12kw	12kw
气源要求	Air Supply	10L/min 0.6Mpa	10L/min 0.6Mpa
整机尺寸	Machine Dimension	L6600×W4100×H3250 mm	L6600×W4100×H3550 mm
机器重量	Machine Weight	6800kg	6800kg
面纸类型	Paper Wrap Type	1	1/2/3

### 产品优势 Product Advantage

#### 1 Long Ear Folding Device [Optional]

成型折耳对推、互搭工艺 (选配)



It can fold the ear size 1/2 Width and 1 Width of box. [Width < 100mm]

可以实现耳朵对推对推工艺。(宽度≤100mm)

#### 2 Mechanical Type Paper Feeder

机械式后吸面纸飞达



Adopt on-line mechanical type paper feeder with simple structure and steady running.

采用整机联动的机械式面纸飞达,结构简单,运行稳定。

#### 3 All Icons Control Panel

全图标式控制面板



Friendly-designed all icons control panel, easy to understand and operate.

人性化设计的全图标式控制面板,形象易懂,方便操作。

#### 4 Hydraulic Rectifying Positioning Device

液压纠偏定位装置



Adopt imported hydraulic rectifying system and photoelectric device for positioning, which efficiently improves the precision.

采用进口液压纠偏系统,进口光电定位,有效保证产品的定位精度。

#### 5 Auto Pasting Box Four Corners

纸盒自动四角贴角

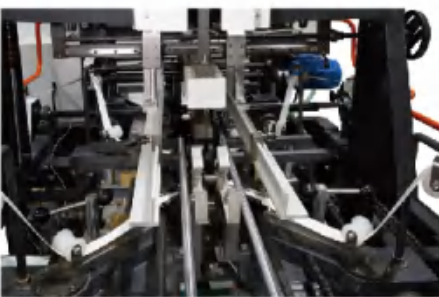

Adopt environment-friendly tape to paste the box corners, which can paste four corners in one process with neat appearance.

采用环保贴角带进行纸盒贴角,四角一次性完成,成品美观整齐。

#### 6 Quality Disc Cam

高品质盘形凸轮



Adopt durable alloy steel disc cams.

采用合金钢材料的盘形凸轮,经久耐用。

# JH3816

## 全自动酒盒成型机



-  Wine Box Making Machine
-  Máquina De Posicionamiento Robot
-  Machine De Positionnement De Robot





# JH3816

## 全自动酒盒成型机

-  Wine Box Making Machine
-  Máquina De Posicionamiento Robot
-  Machine De Positionnement De Robot

### 技术参数 Technical Parameters

型号	Model	JH3816
酒盒尺寸	Size of wine box	Min.90*90*90mm Max. 380*160*160mm
生产速度	Production speed	≤30pcs/min
整机尺寸	Overall size	3666*3482*2415mm
整线尺寸	Whole line size	9990*3666*2415mm
成型机功率	Molding machine power	20kw
整线功率	Whole line power	31kw
气源要求	Air source requirements	60L/min 0.6-0.8Mpa
机器重量	Machine weight	5000kg
定位精度	positioning accuracy	±0.1mm
胶水类型	Glue type	白胶
面纸尺寸	Face paper size	Min: 200*380mm Max: 560*660mm
灰板尺寸	Grey board size	Min: 90*360mm Max: 380*640mm
电源	Power Supply	AC380V
整线重量	Weight of the whole line	8000kg

### 产品优势 Product Advantage

#### 1 Two-station forming 双工位成型



Three camera positioning and mechanical arm clamping box to achieve high-precision positioning.

双工位成型速度更快,大幅度提升工作效率。

#### 2 Servo Controlled Paper Feeder 全新伺服控制的后吸式面纸飞达

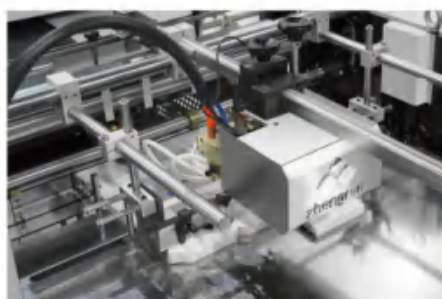

New designed servo controlled paper feeder adopts post-sucking pre-pushing type to convey paper which efficiently avoids two pieces of papers entering into the machine.

全新设计的伺服控制面纸飞达,采用后吸前推送纸,有效防止双张,运行稳定。

#### 3 Visual Image Positioning 视觉影像定位



Visual image positioning and mechanical arm ash feeding plate realize high-precision positioning.

视觉影像定位和机械臂送灰板,实现高精度定位。

#### 4 Servo And Pneumatic Control Structure. 伺服与气动控制结构



The servo and pneumatic control structure completes the hook folding, and the operation is stable.

伺服与气动控制结构完成勾头折边,运行稳定。

#### 5 Adjustable Mold 可调节的模具



It can quickly adjust the mold size, shorten the product change cycle, and realize rapid production.

可快速调节模具尺寸,缩短换产品周期,实现快速投产。

#### 6 Bottom Cover Stacking Conveyor 底盖堆放输送装置



The bottom cover stacking conveyor can realize non-stop transportation and ensure the high-speed operation of the machine.

底盖堆放输送装置,可以实现不停机输送,保证机器的高速运转。

# Automatic Case Maker

## 全自动封面机



### 用途

飞达送面纸、上胶，飞达送纸板，面纸与纸板定位粘合，四边包边一次完成。具有定位准确、快速，成品美观等特点。可以用来制作精装书壳、笔记本封面、台历、挂历、书形盒、文件夹、异形封面等。

### USE

It can automatically feed and glue paper, delivery and position cardboard, and fold four sides in one process; there are features of accurate and quick positioning, and beautiful finished products etc. It is used to make hardcovers, notebook covers, desk calendars, hanging calendars, book-type boxes, files and irregular covers etc.

### 备注 Remark

1. 封面的最大和最小尺寸，取决于面纸的最大和最小尺寸以及面纸的质量。
2. 封面的尺寸大小会影响到机器的速度。
3. 厂家不提供空压机。

1. The max and mini sizes of the covers are subjected to the size and the quality of the paper.
2. The speed of the machine depends on the sizes of the covers.
3. We don't provide air compressor.

### 技术参数图列

Technical Parameter Diagram

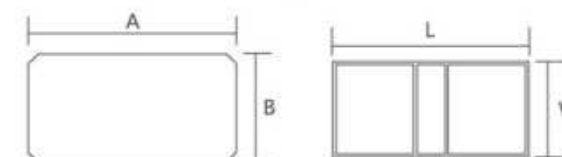

### 封面类型 Cover Type

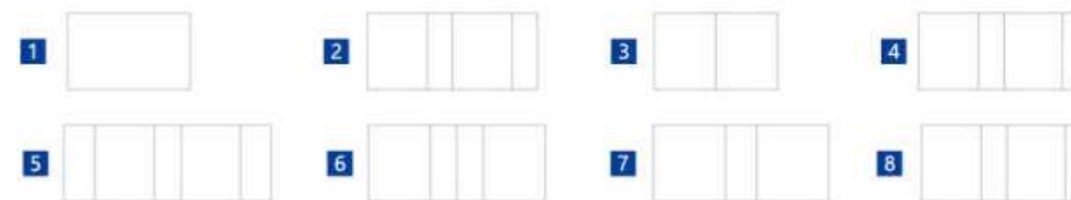

### 生产流程 Production Flow

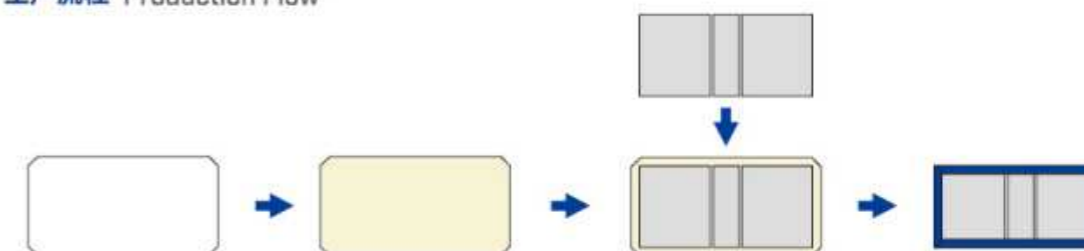

# CM450A/540A/600A

## 全自动封面机

-  Automatic Case Maker
-  Maquina Automática de Tapa Dura
-  Couverturière



### 1 New Paper Feeder

全新的面纸飞达



Fully pneumatic controlled post-sucked type paper feeder is easy to maintenance.

拥有发明专利的后吸式面纸飞达，全气动控制，简单易维护。

### 2 Irregular Case Folding Technology

异形边包边技术



Adopt original folding technology which solves the technical difficulties of irregular case in the field.

采用全球独创的异性边包边技术，解决这个领域的技术难题。

### 3 High-precision Positioning Device

高精度定位装置

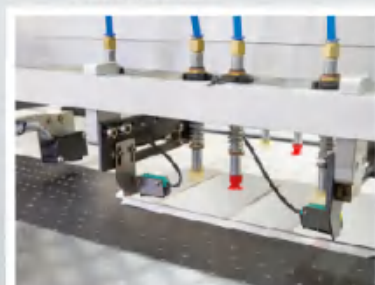

Photoelectric tracking detection servo deviation correction to ensure positioning accuracy.



光电跟踪检测，伺服纠偏，保证定位精度。

### 技术参数 Technical Parameters

型号	Model	CM450A	CM540A	CM600A
封面尺寸	Case Size(W×L)	MIN: 80×180mm MAX: 450×800mm	Min. 80×180mm Max. 540×1000mm	MIN: 120×220mm MAX: 600×1400mm
面纸尺寸	Paper Size(A×B)	MIN: 110×210mm MAX: 480×830mm	Min. 110×210mm Max. 570×1030mm	MIN: 130×230mm MAX: 630×1430mm
内衬尺寸	Inner Paper Size(W×L)	Min. 90×190mm	Min. 90×190mm	Min. 120×220mm
面纸厚度	Paper Thickness	100-300g/m <sup>2</sup>	100-300g/m <sup>2</sup>	100-300g/m <sup>2</sup>
纸板厚度	Cardboard Thickness	1-4mm	1-4mm	1-4mm
中心条宽度	Spine Width(S)	≥7mm	≥7mm	≥7mm
折边尺寸	Folding Size	10-18mm	10-18mm	10-18mm
纸板片数	Cardboard Qty	6pcs	6pcs	6pcs
定位精度	Precision	±0.1mm	±0.1mm	±0.1mm
生产速度	Speed	≤38sheets/min	≤38pcs/min	≤35sheets/min
电机功率	Motor Power	12kw/380v 3phase	12kw/380v 3phase	12kw/380v 3phase
电热功率	Electric Heating Power	12kw	12kw	12kw
气源要求	Air Supply	30L/min 0.6Mpa	30L/min 0.6Mpa	30L/min 0.6Mpa
整机尺寸	Machine Dimension	L7700×W2200×H1700mm	L9500×W2400×H1700mm	L9500×W2600×H1700mm
机器重量	Machine Weight	3500kg	3500kg	3900kg
封面类型	Cover Type	1/2/3/4/5/6/7/8	1/2/3/4/5/6/7/8	1/2/3/4/5/6/7/8

# CM540S

## 全自动裱内衬机

-  Automatic Lining Machine
-  Máquina automática de recubrimiento
-  Ligne de rembourrage



### 生产流程 Production Flow



#### 1 Glue Viscosity Control Configuration (Optional)

胶水粘度控制配置



Auto glue viscosity meter efficiently adjusts the glue stickiness which ensures the quality of finished products.  
自动胶水粘度控制装置能有效控制胶水的粘度,保证胶水的粘性与成品的质量。

#### 2 Double Paper Detector

超声波双张检测



The ultrasonic double paper detector ensures the machine running and reduces the waste.  
超声波双张检测,有效保证机器稳定,减少废品。

#### 3 High-precision Positioning Device

高精度定位装置



Photoelectric tracking detection servo deviation correction to ensure positioning accuracy.  
光电跟踪检测,伺服纠偏,保证定位精度。

#### 4 New Cardboard Feeding Device (Optional)

下吸式送板装置(选配)





Non-stop downward suction type cardboard feeding device efficiently ensures the products without scratches.  
不停机下吸式输送纸板,有效防止成品划伤。

### 技术参数 Technical Parameters

型号	Model	CM540S
封面尺寸	Case Size(W×L)	Min. 100×200mm Max. 540×1000mm
面纸厚度	Paper Thickness	100~300g/m <sup>2</sup>
纸板厚度	Cardboard Thickness(T)	0.8~4mm
定位精度	Precision	±0.1mm
生产速度	Speed	≤38pcs/min
电机功率	Motor Power	9kw/380v 3phase
电热功率	Electric Heating Power	12kw
气源要求	Air Supply	10L/min 0.6Mpa
整机尺寸	Machine Dimension	L6700×W2400×H1700mm
机器重量	Machine Weight	2200kg

# CMD540

## 全自动封面一体机

-  Fully Automatic Case Maker Line
-  Máquina de la cubierta de control totalmente automático
-  Machine de couverture de contrôle entièrement automatique

CBD450/540 (机械手定位)  
全自动视觉封面一体机

CBD 450/540 (Robot positioning)  
Fully automatic visual cover all-in-one machine



( 图为CMD540 反机 ) [Image shows CMD540 reverse machine]

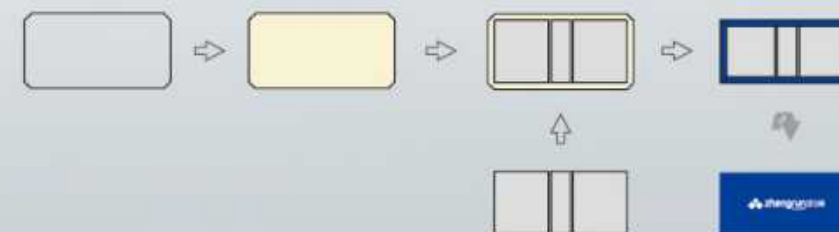



生产流程  
Production Flow



# CMD540

## 全自动封面一体机

-  Fully Automatic Case Maker Line
-  Máquina de la cubierta de control totalmente automático
-  Machine de couverture de contrôle entièrement automatique

### 技术参数 Technical Parameters

型号	Model	CMD540
面纸尺寸	Paper Size(A×B)	Min. 130×230mm Max. 570×1030mm
面纸厚度	Paper Thickness	100-300g/m <sup>2</sup>
纸板厚度	Cardboard Thickness	1-4mm
成品尺寸	Case Size	Min. 100×200mm Max. 540×1000mm
中心条最小尺寸	Min.Spine Width(S)	7mm
折边尺寸	Folding Size	10-18mm
最多可做片数	Cardboard Qty	6pieces
定位精度	Precision	±0.1mm
生产速度	Speed	≤35sheets/min
电机功率	Motor Power	20kw/380v 3phase
电热功率	Electric Heating Power	24kw
气源要求	Air Supply	55L/min 0.6Mpa
机器重量	Machine Weight	6500kg
整机尺寸	Machine Dimension	L12000×W4450×H1800mm

### 产品优势 Product Advantage

#### 1 Yamaha Manipulator 全气动式飞达

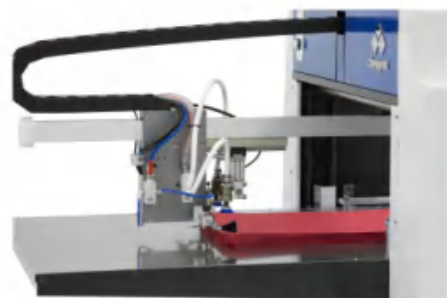

Full-pneumatic Feida: simple mechanism, convenient operation and accurate action.

全气动式飞达,机构简单,操作方便,动作精准。

#### 2 Ultrasonic Double-sheet Inspection 超声波双张纸检测



Ultrasonic double-sheet paper detection can effectively prevent double-sheet paper and reduce waste products.

超声波双张纸检测,有效防止双张纸,减少废品。

#### 3 High-precision Photoelectric Positioning 高精度光电定位



High-precision photoelectric positioning, photoelectric tracking and detection, servo correction to ensure positioning accuracy.

高精度光电定位光电跟踪检测,伺服纠偏,保证定位精度。

#### 4 Trimming Of Motor Parts 电机部件修角



Trimming controlled by stepper motor, adjustable, faster and more accurate

电机部件修角,修角精准,速度快,压紧力度可调。

#### 5 Lining Suction Device (Optional) 内衬下吸装置(选配)



Liner down-suction device is used to down-suction and transport paperboard without stopping the machine, effectively preventing scratches on finished products.

内衬下吸装置,不停机下吸输送纸板,有效防止成品刮伤。

#### 6 Heavy Roll Flattening Device (Optional) 重辊压平装置(选配)





The heavy roll flattening device can effectively remove bubbles and improve flatness with pressure groove function.

重辊压平装置,有效去除气泡,带压槽功能提高平整度。

# CB540

## 机械手两用定位机

-  Robot Positioning Machine
-  Máquina de posicionamiento robot
-  Machine de positionnement de robot



**1 Station I**  
工位一



Cardboard Positioning  
纸板定位

**2 Station II**  
工位二



Box Positioning  
The first domestic three-camera positioning system  
纸盒定位  
国内首创三视觉影像系统

### 技术参数 Technical Parameters

型号	Model	CB540
封面尺寸	Case Size[W*L]	Min. 100x200mm Max. 540x1000mm
纸盒尺寸	Box Size[W*L]	Min. 50x100mm Max. 380x480mm
纸盒高度	Box Height[H]	10-120mm
面纸尺寸	Paper Size[W*L]	Min. 100x200mm Max. 570x1030mm
面纸厚度	Paper Thickness	100-300g/m <sup>2</sup>
纸板厚度	Cardboard Thickness[T]	1-4mm
定位精度	Precision	±0.1mm
生产速度	Speed	<35pcs/min
电机功率	Motor Power	8kw/380v 3phase
电热功率	Electric Heating Power	12kw
气源要求	Air Supply	10L/min 0.6Mpa
整机尺寸	Machine Dimension	L7350xW3520xH2000mm
机器重量	Machine Weight	2200kg

# JB450/540/650/800

## 酒包定位机

-  Wine Bag Positioning Machine
-  Máquina De Posicionamiento De Paquetes De Vino
-  Machine De Positionnement De Paquet De Vin



- 1 Servo Controlled Paper Feeder**  
全新伺服控制的后吸式面纸飞达
- 2 Visual Image Positioning**  
视觉影像定位
- 3 Glue Viscosity Control Configuration [Optional]**  
胶水粘度控制配置



New designed servo controlled paper feeder adopts post-sucking pre-pushing type to convey paper which efficiently avoids two pieces of papers entering into the machine.

全新设计的伺服控制面纸飞达,采用后吸前推送纸,有效防止双张,运行稳定。



Visual image positioning and mechanical arm ash feeding plate realize high-precision positioning.

视觉影像定位和机械臂送灰板,实现高精度定位。



Auto glue viscosity meter efficiently adjusts the glue stickiness which ensures the quality of finished products.

自动胶水粘度控制装置能有效控制胶水的粘度,保证胶水的粘性与成品的质量。

### 技术参数 Technical Parameters

型号	Model	JB450	JB540	JB650	JB800
面纸尺寸	Paper Size(W×L)	MIN:130X230	MIN:130X230mm	MIN:130X230mm	MIN:130X230mm
		MAX:480X830	MAX:570X830mm	MAX:580X830mm	MAX:800X830mm
面纸厚度	paper Thickness	100-300g/m <sup>2</sup>	100-300g/m <sup>2</sup>	100-300g/m <sup>2</sup>	100-300g/m <sup>2</sup>
纸板厚度	Cardboard Thickness(T)	1-3mm	1-3mm	1-3mm	1-3mm
成品尺寸	Finished Size	MIN:100X200mm	MIN:100X200mm	MIN:100X200mm	MIN:100X200mm
		MAX:450X800mm	MAX:540X1000mm	MAX:450X800mm	MAX:450X800mm
中心条宽度	Spine Width(S)	7mm	7mm	7mm	7mm
最多可做片数	Maximum Number Of Slices	6pieces	6pieces	6pieces	6pieces
定位精度	Precision	±0.1mm	±0.1mm	±0.1mm	±0.1mm
生产速度	Speed	≈35pcs/min	≈35pcs/min	≈35pcs/min	≈35pcs/min
电机功率	Motor Power	8kw/380v 3phase	8kw/380v 3phase	8kw/380v 3phase	8kw/380v 3phase
电热功率	Electric Heating Power	12kw	12kw	12kw	12kw
气源要求	Air Supply	10L/min 0.6Mpa	10L/min 0.6Mpa	10L/min 0.6Mpa	10L/min 0.6Mpa
整机尺寸(mm)	Machine Dimension	5450X2200X2000	L6250×W2460×H2000	L6280×W2300×H2000	L6280×W2400×H2000
机器重量	Machine Weight	2000kg	2200kg	2400kg	2500kg



# CB450A/540A

## 全自动视觉封面机

 Automatic Case Maker (Visual Positioning)

 Maquina Automática de Caja Rigida

 Ligne de machines à boîte

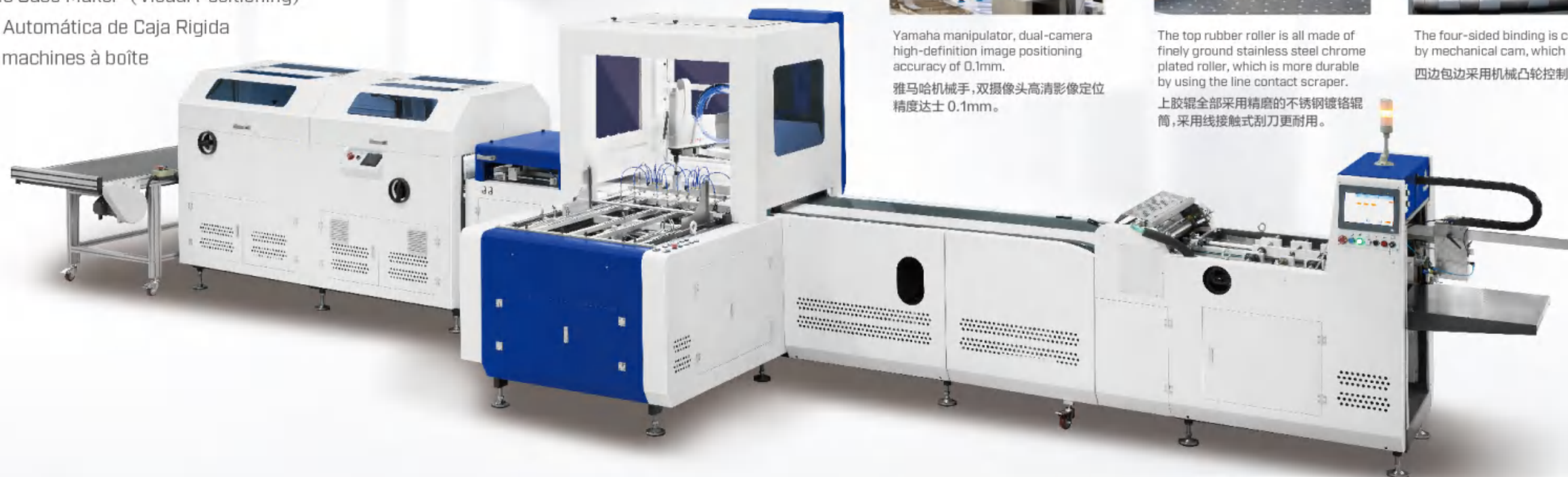

### 1 Yamaha Manipulator 雅马哈机械手定位



Yamaha manipulator, dual-camera high-definition image positioning accuracy of 0.1mm.  
雅马哈机械手,双摄像头高清影像定位精度达±0.1mm。

### 2 Stainless steel chrome-plated roller 不锈钢镀铬辊筒



The top rubber roller is all made of finely ground stainless steel chrome plated roller, which is more durable by using the line contact scraper.  
上胶辊全部采用精磨的不锈钢镀铬辊筒,采用线接触式刮刀更耐用。

### 3 Mechanical Cam Control Is Adopted For Four-side Binding 四边包边采用机械凸轮控制

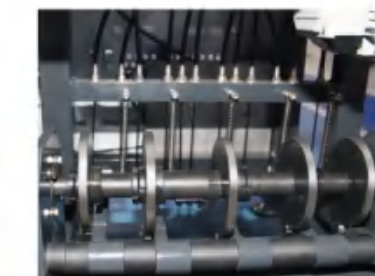

The four-sided binding is controlled by mechanical cam, which is durable.  
四边包边采用机械凸轮控制,经久耐用。

### 技术参数 Technical Parameters

型号	Model	CB450A	CB540A
面纸尺寸	Face paper size	MIN: 100×230mm MAX: 480×830mm	MIN: 100×230mm MAX: 570×1030mm
面纸厚度	Top paper thickness	100-300g/m <sup>2</sup>	100-300g/m <sup>2</sup>
纸板厚度	Cardboard thickness	1-4mm	1-4mm
成品尺寸	Finished product size	MIN: 100×200mm MAX: 450×800mm	MIN: 100×200mm MAX: 540×800mm
中心条最小尺寸	Minimum size of center bar	7mm	7mm
折入纸边尺寸	Folded edge size	10-18mm	10-18mm
最多可做片数	Maximum number of slices	6pieces	6pieces
定位精度	positioning accuracy	±0.1mm	±0.1mm
生产速度	Production speed	< 35sheets/min	< 35sheets/min
电机功率	Motor power	12kw/380v 3phase	12kw/380v 3phase
电热功率	Electrothermal power	12kw	12kw
气源要求	Air source requirements	30L/min 0.6Mpa	30L/min 0.6Mpa
机器重量	Machine weight	3200kg	3500kg
整机尺寸	Overall size	L9450×W2200×H2000mm	L11100×W2500×H2000mm



**KL1300A** | (单机)  
Single Machine

**KL1300AS** | (纵横线)  
Assembly Line

**KL1300ASB** | (带飞达)  
Assembly Line With Feeder

**KL1300ASD** | (带飞达带自动收料)  
Assembly Line With Feeder&collector

### 全自动纵横纸板分切机

-  Cardboard Cutter
-  Cortador de Carton Tapa Dura
-  Coupeuse à rtons

### 生产流程 Production Flow

注：厂家不提供空气压缩机  
Remark: We don't provide air compressor

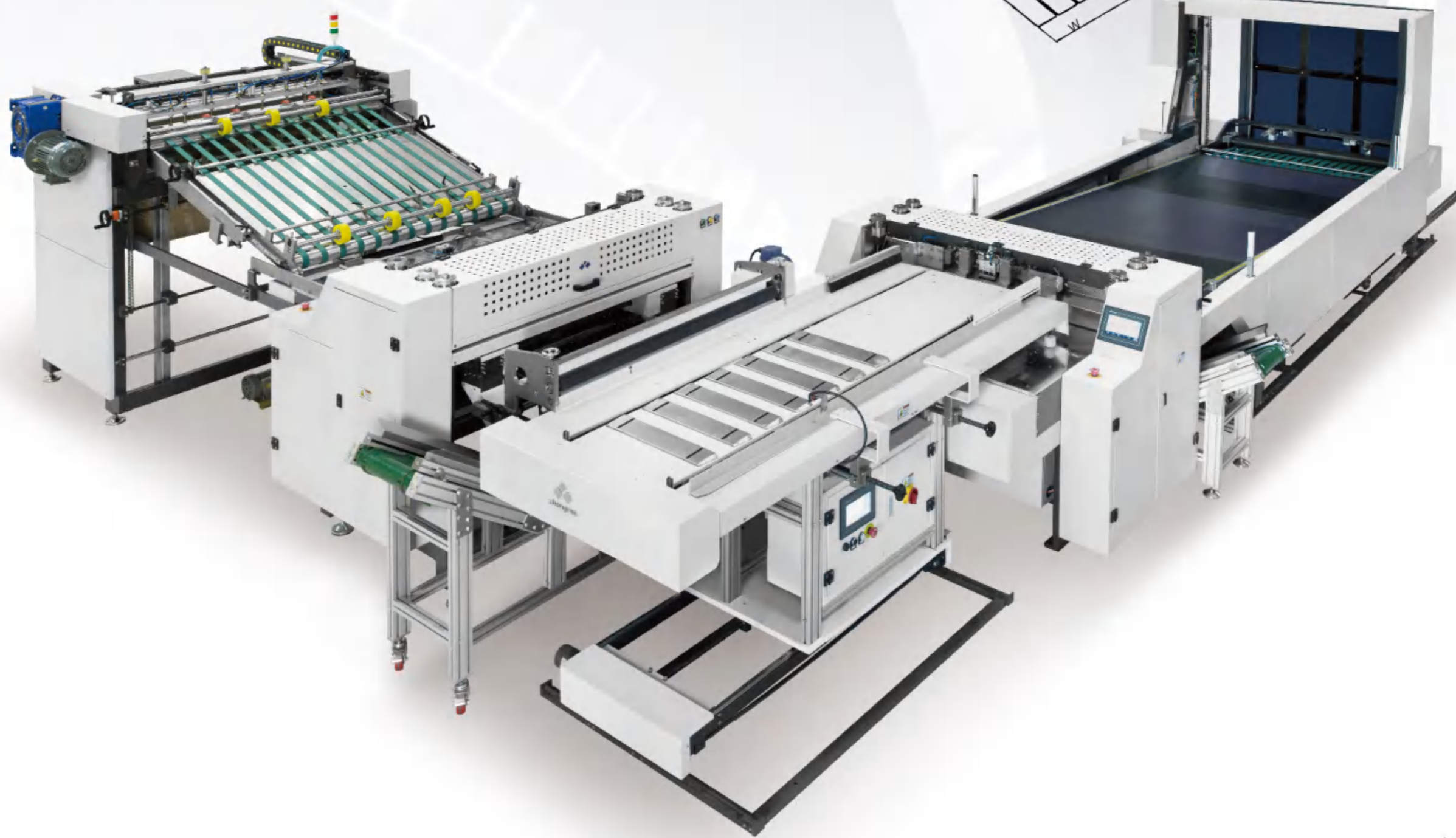
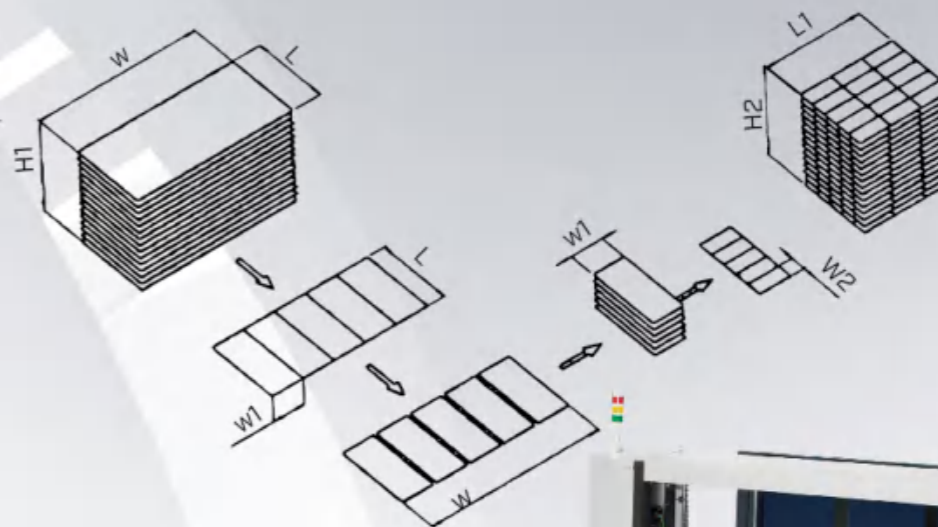



**KL1300A** | (单机)  
Single Machine

**KL1300AS** | (纵横线)  
Assembly Line

**KL1300ASB** | (带飞达)  
Assembly Line With Feeder

**KL1300ASD** | (带飞达带自动收料)  
Assembly Line With Feeder&collector

## 全自动纵横纸板分切机

-  Cardboard Cutter
-  Cortador de Carton Tapa Dura
-  Coupeuse à rtons

### 技术参数 Technical Parameters

型号	Model	KL1300A	KL1300ASD
大纸板尺寸	Cardboard size	W<1300mm L<1300mm W1=100-900mm W2>55mm	Max. W1100mm×L1260mm Min. W620mm×L620mm
纸板厚度	Cardboard thickness	1-4mm	1-4mm
送纸堆最大高度	Stacking height		1500mm
收料堆最大尺寸	Maximum size of receiving pile		1500mm
第一刀成品尺寸	First cutting size		W1 140-520mm L 620-1100mm
第二刀成品尺寸	Second cutting size		W1 140-520mm W2 55-1100mm
裁切精度	Cutting Accuracy	±0.1mm	±0.1mm
生产速度	Speed	≤40pcs/min	≤40pcs/min
整机功率	Power	4kw/380v 3phase	16.2kw/380v 3phase
气源要求	Air supply	0.1L/min 0.6Mpa	7L/min 0.6Mpa
机器重量	Machine weight	1300kg	5500kg
机器尺寸	Machine dimension	L3260×W1815×H1225m	L10160×W6000×H1930mm

### 产品优势 Product Advantage

**1 Auto Board Feeder**  
自动送纸飞达



Max height of Stack can up to 1.5 meter. Full servo control. Paper feeding high speed and stably.

送纸堆高度可达1.5米，全伺服控制，送纸高速稳定。

**2 High Quality Round Knife**  
高品质圆刀



Using alloy material round knife, durable, effectively reduce wear and improve cutting efficiency.

采用合金材料圆刀，经久耐用，有效减少磨损，提高分切效率。

**3 Pneumatic Pressure Control Device**  
气动压力控制装置



Pneumatic pressure adjustment, convenient and fast, reduce the technical personnel on the machine operation requirements.

气动压力调节，方便快捷，减低技术人员对机器的操作要求。

**4 Ball Screw With Servo Motor**  
滚珠丝杆配伺服电机



The feeder adopts servo motor and ball screw, which improves the accuracy and makes the adjustment easier.

材料推头采用伺服电机配合滚珠丝杆进料，提高精度，调节更简单。

**5 Numerical Knife Adjustment**  
刀具调节数值化



Digital setting of knife spacing, according to the setting, the gauge automatically moves to the designated position, easy to adjust, no need to measure.

数字化设置刀具间距，根据设定，靠规自动移动到指定位置，方便调节，无需测量。

**6 Waste Removal Device**  
除废装置





After the board is cut, the left and right wastes are automatically send to the crusher, and then conveyor belt send them out of machine, which is simple and practical, and reduces the labor intensity.

裁切后，左右废料自动进入粉碎机，再由输送带送出机器，简洁实用，降低劳动强度。

# KX650SD

## 全自动开板开槽一体机

-  Cardboard Cutting and slotting machine
-  Máquina automática de ranura y costura
-  Machine de fente automatique

### 功能特点 Functional Features

更快捷、更高效、一次成型，高精成品

Faster And More Efficient  
One-shape, High Precision Finish

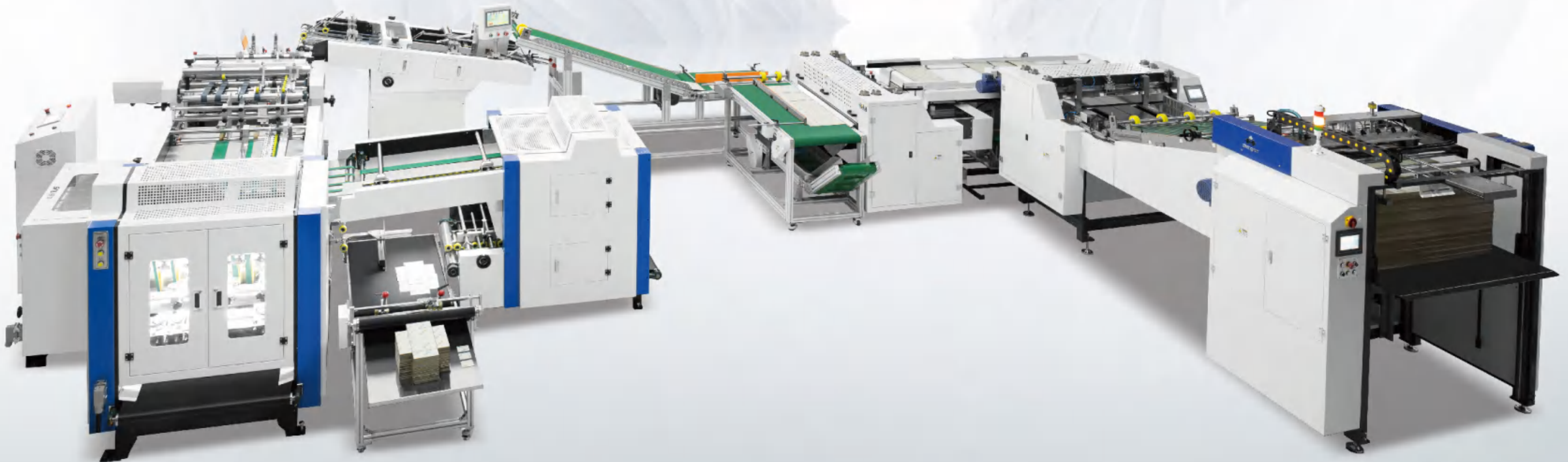

### 机器参数 Machine Parameters

型号	Model	KX650SD
大纸板尺寸	Large Cardboard Size	Min 620 X 620mm Max 1100 X 1260mm
纸板分切成品尺寸	Paperboard Slitting Finished Size	Min 55*140mm Max 520*1100mm
开槽成品尺寸	Slotted Finished Size	Min 120*120mm Max 550*600mm
纸板厚度	Paperboard Thickness	1.5-3.5mm
堆纸高度	Stack Height	1500mm
裁切精度	Cutting Accuracy	±0.1mm
裁切速度 (开大板)	Cutting Speed (Open Large Boards)	< 40pcs/min(300 X300mm)
运行速度	Running Speed	< 120pcs/min(300 X300mm)
开槽角度	Slotting Angle	90°-130°
槽间距精度	Accuracy Of Slot Spacing	±0.1mm
割线长度范围	Range of cut line lengths	15-120mm
割线过头	Cutting the line too far	< 2mm
第一道开槽条数	Number of grooved strips in the first course	8条
第二道开槽条数	Number of grooved strips in second course	4条
总功率	Total power	22.2kw/380v 3phase
气源要求	Air supply requirements	2L/min 0.6Mpa
机器重量	Machine weight	10000kg
机器尺寸	Machine size	L9700*W6400*H1910mm



# CW380

## 全自动围框机

-  Fully automatic framing machine
-  Máquina de cerco totalmente automática
-  Machine de cerclage entièrement automatique

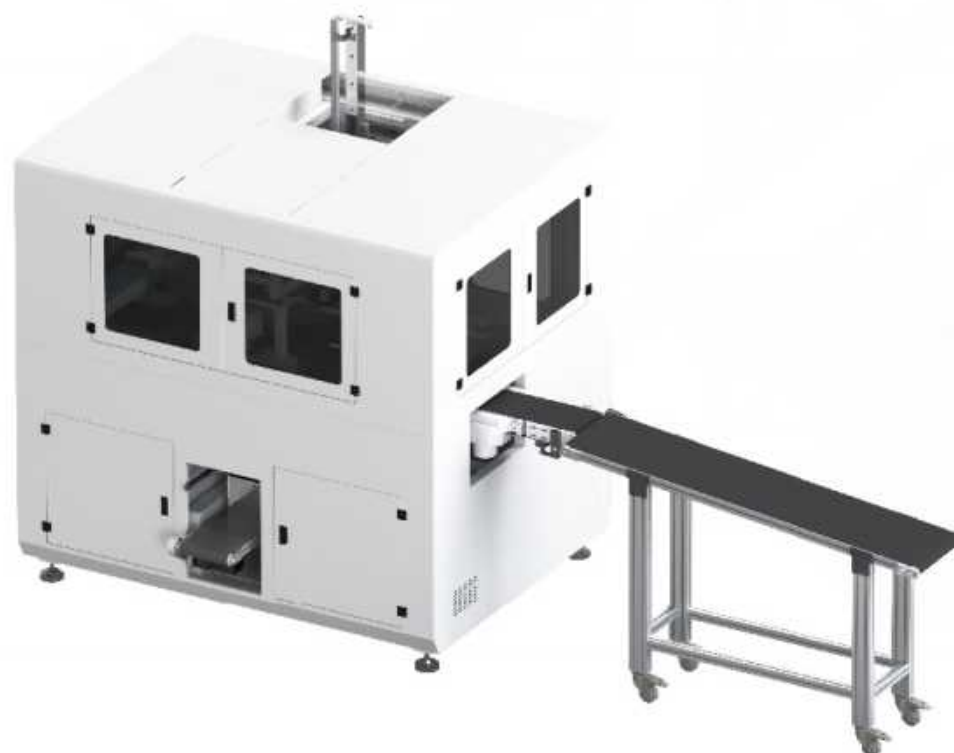



技术参数 Technical Parameters

型号	Model	CW380
成型尺寸	Forming size	min: 195*60*30mm max: 380*160*200mm
面纸回折	Face paper folding back	min: 15mm max: 120mm
面纸尺寸	Paper Size	min: 520*30mm max: 1090*320mm
纸板尺寸	Cardboard size	min: 510*30mm max: 1080*200mm
纸板厚度	Cardboard Thickness	1-3mm
面纸厚度	Paper Thickness	100-200g/m <sup>2</sup>
生产速度	Speed	<20pcs/min
整机功率	Power	7kw
气源要求	Air Supply	60L/min 0.6-0.8Mpa
定位精度	precision	±0.1mm
电源	Power Supply	AC380V
整机尺寸	Machine Dimension	1890*1430*2173mm
机器重量	Machine weight	1500kg

# ATJ600/380

## 自动贴角机

-  Automatic Corner Pasting Machine
-  Pegadora de esquina automática
-  Colleuse de coins automatique





技术参数 Technical Parameters

型号	Model	ATJ600	ATJ380
纸盒最大尺寸	Maximum carton size	600*400mm	380*260mm
纸盒最小尺寸	Minimum carton size	50*50mm	50*50mm
纸盒高度尺寸	Tray height dimension	10-185mm	10-120mm
生产速度	Production speed	≤46sheets/min	≤50sheets/min
电机功率	Motor power	3kw/380v 3phase	3kw/380v 3phase
电热功率	Electrothermal power	1.6kw	1.6kw
气源要求	Air source requirements	2L/min -0.6Mpa	2L/min 0.6MPa
纸板厚度	Board thickness	0.8-3mm	0.8-3mm
机器重量	Machine weight	1800kg	1400kg
整机尺寸	Overall size	L3000*W3250*H3050mm	L2250*W2500*H2450mm

# ZX450

## 中心条分切机

-  Spine Cutter
-  Cortador de Espina
-  Coupe dos

### 生产流程 Production Flow

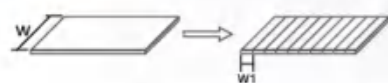

### 1 Ce Safety Cover CE安全罩壳



### 2 Width Adjustment 宽度调节



### 3 Finished Products 成品





The precision of finished products is 0.1mm  
成品精度达到0.1mm

### 技术参数 Technical Parameters

型号	Model	ZX450
纸板宽度	Cardboard Width	W<450mm W1=7-45mm
纸板厚度	Cardboard Thickness	1-3mm
分切速度	Speed	180pcs/min
电机功率	Power	1.1kw/380v 3phase
机器重量	Machine Weight	850kg
机器尺寸	Machine Dimension	L1130xW1000xH1360mm

# QJ80

## 切角机

-  Angle Cutter
-  Cortador de Esquinas
-  Coupe coins

### 生产流程 Production Flow

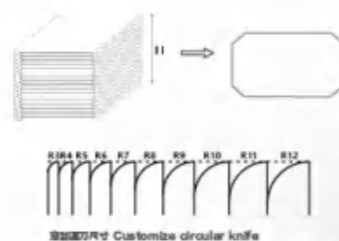



### 技术参数 Technical Parameters

型号	Model	QJ80
纸张高度	Paper Height (H)	≤80 mm
切角速度	Speed	85 times/min
工作平台	Work Table	580x580mm
整机功率	Power	0.75kw/380v 3phase
机器重量	Machine Weight	270kg
机器尺寸	Machine Dimension	L1350xW500xH1200mm

# ZR9060

## 全自动磁铁（铁片）机

-  Magnet (steel disc) pasting machine
-  Máquina magnética (SMT)
-  Magnetplazierung Maschine



### 技术参数 Technical Parameters

型号	Model	ZR9060
纸板尺寸	Paperboard size	Max. L900*W600mm Min. L120*W90mm
磁片直径	Magnet diameter	6-20mm
生产速度	Product speed	30-40pcs/min
定位精度	Positioning accuracy	±0.1mm
纸板厚度	Card board thickness	1-3mm
工作气压	Pressure	0.6-0.8Mpa
整机功率	Power	5kw/220V
整机尺寸	Machine dimension	L3035*W1670*H1530mm
机器重量	Weight	750kg



# FB650

## 全自动书型盒组装机

-  Automatic Book Style Box Assembling Machine
-  libro de caja automática de instalada
-  La puissance du type n'établit boîte

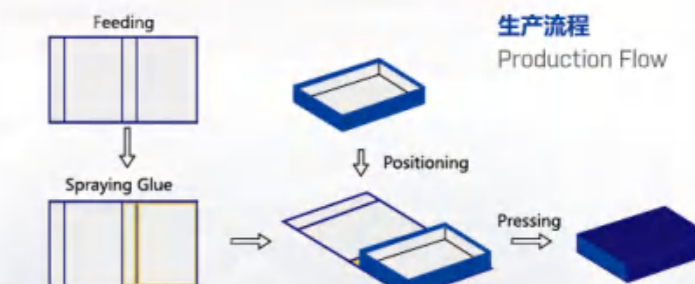



### 技术参数 Technical Parameters

型号	Model	FB650
皮壳尺寸	Case Size	Min. 110x160mm Max. 450x950mm
生产速度	Speed	22pcs/min
电机功率	Motor Power	6kw/380v 3phase
气源要求	Air Supply	0.5-0.8Mpa
整机尺寸	Dimension	L4000xW1600xH1900mm
机器重量	Machine Weight	1800kg



# KC1000

## 全自动开槽机

-  Automatic Groover
-  Maquina Automatica para Sanjas
-  Fraiseuse automatique





### 技术参数 Technical Parameters

型号	Model	KC1000
纸板宽度	Cardboard Width	130-950mm
纸板长度	Cardboard Length	50-800mm
开槽精度	Grooving Accuracy	±0.1mm
生产速度	Speed	150-200pcs/min (150×150mm)
开槽角度	Grooving Degree	70-110° 110-135°
板材厚度	Cardboard Thickness	300gsm-3.0mm
开槽条数	Groove Qty.	9pcs
整机功率	Power	2.2kw/380v 3phase
整机尺寸	Dimension	L1900×W1500×H1450mm
整机重量	Machine Weight	1500kg

# BF450

## 气动纸盒成型机

-  Pneumatic Box Wrapper
-  Envolvedora de Cajas
-  Emballeuse





### 技术参数 Technical Parameters

型号	Model	BF450
纸盒尺寸	Case Size	Min. 50x70mm Max. 450x450mm
纸盒高度	Box Height	10-120mm
生产速度	Speed	18-25pcs/min
电机功率	Motor Power	2.5kw/220v
气源要求	Air Supply	0.8Mpa
整机尺寸	Dimension	L1400×W1200×H1900mm
机器重量	Machine Weight	1000kg

# ZHYP380

## 全自动压泡机

-  Box Pressing Machine
-  Prensa de caja
-  Machine de boîte de pression





### 技术参数 Technical Parameters

型号	Model	ATJ380
最大产品规格	Maximum product specification	L380*W260*H120mm
最小产品规格	Minimum product specification	L100*W50*H10mm
生产速度	Production speed	<25pcs/min
电机功率	Motor power	0.5kw/380V
气源要求	Air source requirements	420L/min 0.5-0.8Mpa
机器尺寸	Overall size	L3000×W1170×H2450mm
机器重量	Machine weight	870kg

# ZHYP600

## 全自动压泡机

-  Box Pressing Machine
-  Prensa de caja
-  Machine de boîte de pression



### 技术参数 Technical Parameters

型号	Model	ZHYP600
最大产品规格	Maximum product specification	L600*W400mm
最小产品规格	Minimum product specification	L100*W50mm
产品高度	Product height	12-185mm
生产速度	Production speed	<25pcs/min
整机功率	Overall power	6.2kw/380V
气源要求	Air source requirements	10L/min 0.8Mpa
液压系统压力	Hydraulic system pressure	0.5-10Mpa
液压系统工作压力	Working pressure of hydraulic system	0.5-7Mpa
机器尺寸	Machine size	L3150×W1330×H2600mm
机器重量	Machine weight	1010kg

# THE HISTORY OF ZHENGRUN

## 无限未来

起步阶段 梦想开始，不断努力。  
Starting stage

1997.07  
瑞安市富达印刷机械厂成立(正润前身)  
Found Ruian Fuda(currently called Zhengrun)



2002 开始生产半自动封面机与半自动天地盖制盒机  
Began to produce semi-auto case maker and semi-auto rigid box maker.

2005 全自动封面机开始销售  
Began selling fully automatic case maker

2006 RB6040全自动天地盖制盒机开始销售  
Began to sell RB6040 Automatic rigid box maker.

2007.08 搬迁到瑞安经济开发区更名为浙江正润  
Moved to ruian economic development zone renamed to zhejiang zhengrun.

2008-2016  
发展阶段 快速发展，不断创新。  
Development Stage

2010 搬迁至平阳厂房  
成立温州正润  
Moved to Pingyang  
Found Wenzhou Zhengrun.



2012 国家高新技术企业  
CX420纸盒成型机成功研发  
国家火炬计划  
温州市著名品牌  
温州市产品研发中心  
National High-tech Enterprise  
Began to develop and manufacture CX420 box wrapper  
State Torch Program enterprise  
Wenzhou name brand Wenzhou Product R/D Center

2013 CM540A新型封面机成功研发  
RB420全自动制盒机成功研发  
CM540A Automatic case maker and RB420 Automatic rigid box maker

2014 RB185全自动天地盖制盒机推广  
HCM390全自动高速书壳机推广  
平阳滨海园区新厂房开工建设  
Began to sell RB185 Automatic rigid box maker and HCM390 High speed case maker  
Began to build new workshop in Binhai high-tech park, Pingyang

2016 RB240全自动天地盖制盒机研发成功，开始销售  
CR400圆角机研发成功，开始销售  
RB240 automatic rigid box making machine  
CR400 corner rounding machine

2017-PRESENT  
腾飞阶段 走向国际，展望未来。  
Take-off Stage



2017 正润20周年20years  
搬迁至第四期  
花园式厂房  
Moved to garden-like factory in February

2018 纵横纸板分切机KL1300AS  
研发成功、开始销售  
CMD540全自动封面一体机  
研发成功、开始销售  
KL1300AS Cardboard cutter  
CMD540 Fully automatic case maker line

2019 第三届中德集团全能纸包装论坛暨演示会在正润举办  
The 3rd Zhongde Group Universal Paper Packaging Forum and Demonstration Conference was held in Zhengrun

2020 RB380全自动天地盖制盒机(双工位)  
研发成功、开始销售  
RB380 Automatic rigid box maker(double station)



2021 RB380B 全自动纸盒成型机研发成功开始销售  
被评为浙江省“专精特新”中小企业  
北京国际印刷展2021  
RB380B Automatic rigid box maker was successfully developed.  
Won the title of "specialized and sophisticated small and medium enterprises" in Zhejiang Province.  
China Print 2021 in Beijing

2022 JH3816 全自动酒盒成型机研发成功开始销售  
全自动书型盒柔性生产线设备智能联网  
全面推进信息化，数字化管理  
被评为“浙江制造品字标”认证企业  
JH3816 Automatic wine box making machine was successfully developed.  
Automatic book type box flexible production line equipment intelligent connection.  
Comprehensively promote informatization and digital management.  
Won the title of "Zhejiang makes it happens" certification enterprise.

2023 RB380S全自动纸盒成型机(双盒双定)  
研发成功开始销售  
RB380S Automatic Rigid Box Maker Successfully Developed And Started Selling.





## EXTREME PERFORMANCE SHOCK PERFORMANCE

## 极致性能 震撼表现

我们从不松懈对产品质量的重视

We Are Clear That It Is The Critical Foundation  
For An Enterprise To Improve Quality Of Products



远销全球80多个国家  
Exported To Over 80 Countries  
Worldwide.



先进的7s管理  
Advanced  
7s management



50多项国家专利  
More than 50  
national patents



24年的沉淀与累积  
24 years of sedimentation  
and accumulation



项智能系统  
Item Intelligence  
System



60多个国际品牌合作伙伴  
More than 60  
international brand partners



先进加工设备  
Advanced Processing  
Equipment

我们承诺始终不渝的提高产品质量,不断创新革新,  
努力树立印后包装领域供应商的卓越标杆。

Our promise is to continuously upgrade the quality  
of products and to keep technical innovation be a  
classic supplier of post-press packaging machinery.







检测+

我们的检测协议让您始终有备无患,每次检测后,我们的服务专家都将提供详细的状态报告。

Detection+

Our testing protocol allows you to always be prepared After each inspection, our service experts will provide detailed status reports



高品质+

确保设备生产的最高品质! 高品质加强一系列服务选项。

+High quality

To ensure that the highest quality equipment production! High quality enhances a range of service options.

小时/Hour  
**24-7-12**

制售后服务

24-7-12 Hour After Sales Service

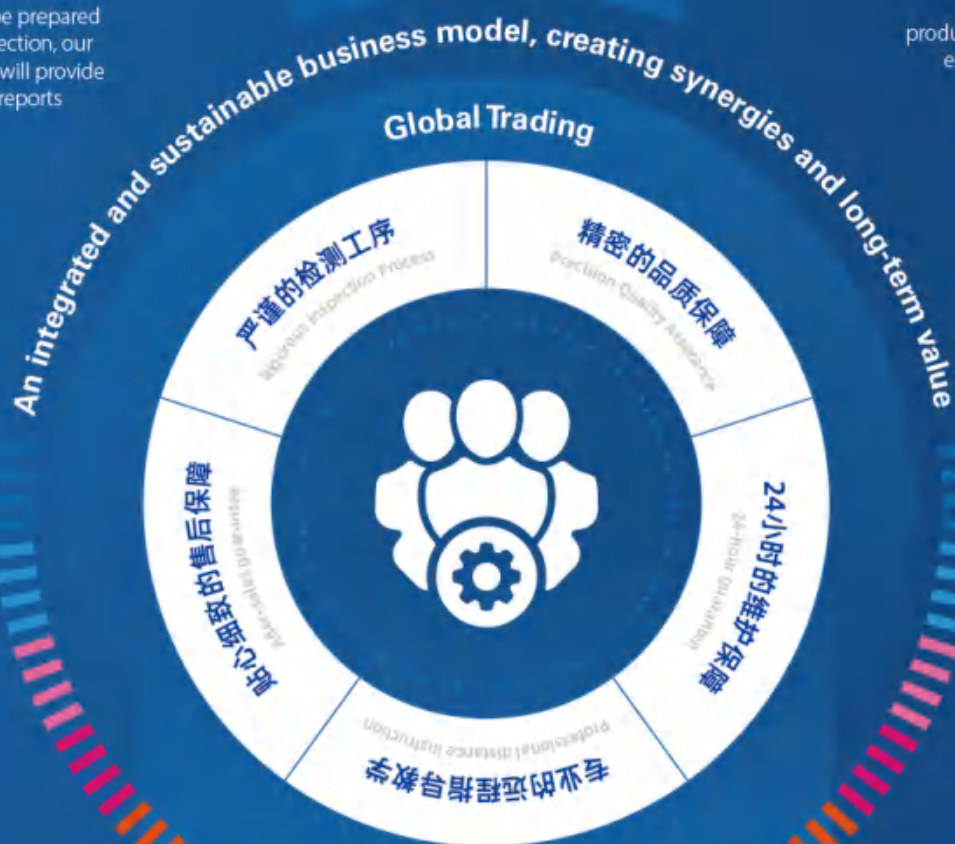

维护+

来自制造商的专业维护能确保设备的最高可用性。

Maintenance+

Professional maintenance from the manufacturer ensures the highest availability of the device

我们始终不渝的重视产品质量,把高质量的材料、严格的制造标准及质量管理体系紧密结合,并不断完善售后服务体系。无论用户身在何处,都会得到及时的响应与支持,享受详尽的最新产品资讯与一流的售后服务。

We always attach importance to product quality, closely combine high-quality materials, strict manufacturing standards and quality management system, and constantly improve after-sales service system. No matter where the user is, he/she will receive timely response and support, enjoy detailed latest product information and first-class after-sales service.



服务能力+

我们为您提供设备维护支持,并使您获知如何应对设备故障问题。

Service capabilities+

We provide you with equipment maintenance support and information on how to deal with equipment problems.

环境条件 Ambient Conditions



温度: 环境温度须保持在 18-24°C 左右 (夏天需配备空调装置)。

Temperature: The ambient temperature must be maintained at about 18-24 °C [air conditioning devices are required in summer].



避免与产生震动、高频电磁的机器相邻。

To keep the machine from vibrating and shaking and being next to the electric apparatus with high-frequency electromagnetic field.



避免与太阳直接照射。

To keep it from being directly exposed to the sun.



湿度: 环境湿度应控制在 50%-60% 左右。纸板湿度: 13% 以下。

Humidity: The humidity should be controlled around 50%-60%.



远离油气、化学物、酸性、碱性及爆炸物或易燃物。

To be away from oil gas, chemicals, acidic, alkali, explosive and inflammable substances.



照明: 300LUX 以上, 以保证光电部件的正常工作。

Lighting: above 300LUX that can ensure the photoelectric components can work regularly.



十分呵护 十分品质

Take Good Care Of Quality



气源要求 Air source requirements

空气质量不良是气动系统出现故障的最主要原因, 它会使气动系统的可靠性和使用寿命大大降低, 由此造成的损失会大大的超过气源处理装置的成本和维修费用, 故正确配置气源处理系统及其元件是非常重要的。以下空气净化处理方案可供参考 (由用户自备)

The poor quality of air will mainly cause malfunctions of the pneumatic system. It will seriously reduce the reliability and the life of the system, which will result in grave loss that may be abundantly exceed the costs used to remedy the malfunctions and maintain the equipment. Therefore It is very important for the user to allocate its air supply system and its components. The following air purifying methods are for your reference only. (Provided by customer)

材料要求 Material Requirements

- 1、面纸、纸板必须保持平整, 纸板的湿度应控制在9%-13%
- 2、面纸覆膜的必须进行双面静电处理

1. The paper and cardboards should be kept flat all the time. The humidity of cardboards should be kept around 9% to 13%.
2. The film-laminated paper should be electro-statically treated in double side.

流程图 Flow Chart

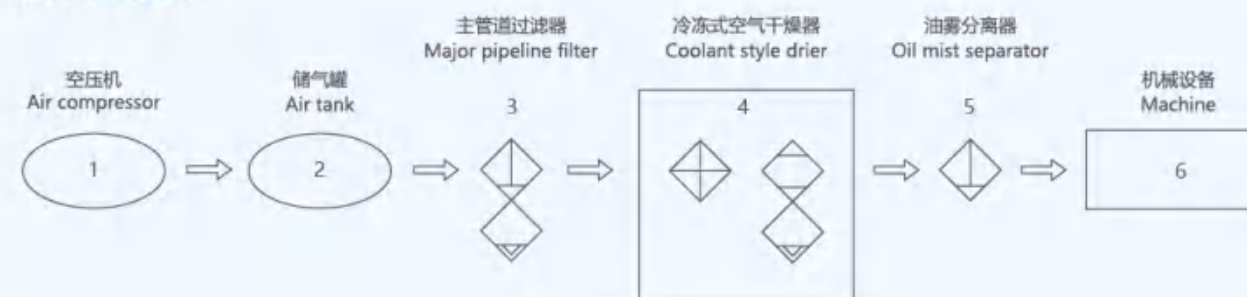

## 中德集团简介

Zhongde Group Introduction

中德集团成立于2002年。集团下辖成员单位有：上海天岑机械制造有限公司、浙江华岳包装机械有限公司、浙江劲豹机械有限公司、浙江正润机械有限公司、瑞安华威印刷机械有限公司。集团立足印刷包装行业，为广大顾客提供国内具有先进技术水平印前、印后设备。产品有各类全自动覆膜机、上光机和喷码机，程控切纸机和裁切线、高速异性贴窗机，全自动丝网印刷机，全自动天地盖制盒机、全自动封面机、酒盒生产线设备等。集团技术实力雄厚，制造工艺先进，品种门类齐全，服务快捷周到。欢迎广大顾客垂询。

Set up in the year of 2002, Zhongde Group has the subsidiaries, i.e. Shanghai Tiancen Machinery Manufacture Co., Ltd., Zhejiang Huayue Packaging Machinery Co., Ltd., Zhejiang Jinbao Machinery Co., Ltd., Zhejiang Zhengrun Machinery Co., Ltd. and Ruian Huawei Printing Machinery Co., Ltd.. Based on the printing industry, the Group is offering the massive clients with advanced pre-printing and post-printing machineries. The products cover all specifications of full auto film laminators, calendaring machines, code inkjet printers, programmable paper cutter, slitter, high-speed a anisotropic window plasters, full auto mesh screen printers, full auto up-bottom-cover box machine, full auto cover machines and alcohol box production assemble lines. The Group has strong technical force and advanced technology and larger range of specifications of products. We are ready to offer the users fast and all-round classic service. Welcome to call us for more information.

### 集团成员

上海天岑机械制造有限公司  
 浙江华岳包装机械有限公司  
 浙江劲豹机械有限公司  
 浙江正润机械有限公司  
 温州天岑机械有限公司

### Group Members

Shanghai Tiancen Machinery Manufacturing Co., Ltd.  
 Zhejiang Huayue Packing Machinery Co., Ltd.  
 Zhejiang Jinbao Machinery Co., Ltd.  
 Zhejiang Zhengrun Machinery Co., Ltd.  
 Wenzhou Tiancen Machinery Co., Ltd.

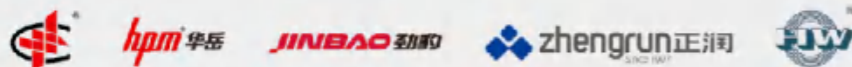

**全自动热刀覆膜机**  
 Automatic hot knife laminating machine

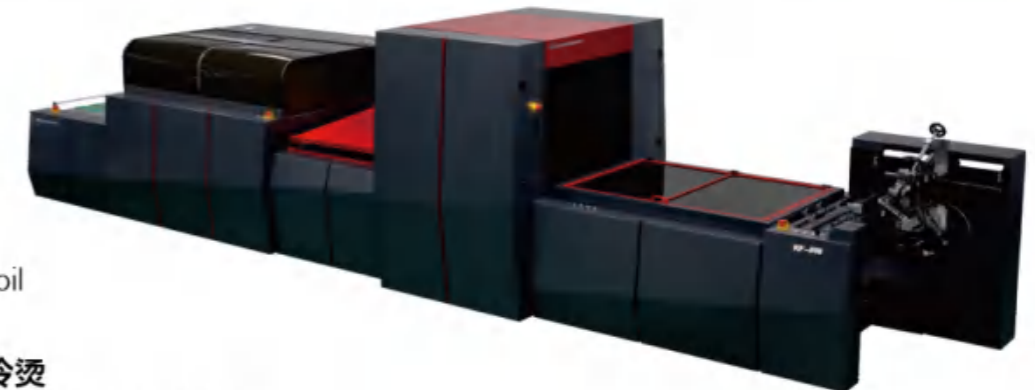

**数字UV冷烫机**  
 Digital Spot UV and Foil

**UV数字增效上光 / 冷烫**  
 Digital effect increase -- Make creativity

**上海天岑机械制造有限公司**  
 SHANGHAI TIANCEN MACHINERY MANUFACTURE CO., LTD.

地址：上海市松江区赵家泾路458号  
 Add.:458 Zhao Jia Jing Rd, Shanghai 201611, China  
 电话：021-37601577  
 传真：021-37601586  
 www.tiancen.cn  
 tc@tiancen.cn

**浙江天岑科技有限公司**  
 ZHEJIANG TIANCEN TECHNOLOGY CO., LTD.

地址：浙江省温州市平阳县滨海新区新阳路13-17号  
 Add:No. 13-17, Xinyang Road, Binhai New Area,  
 Pingyang County, Wenzhou  
 电话：0577-65609888  
 Tel.:0086-577-65609888

**JINBAO 劲豹**



劲速系列

## JB-106AS

Automatic servo con  
screen printing press  
智能伺服型全自动丝网印刷机



**浙江劲豹机械有限公司**  
ZHEJIANG JINBAOMACHINERY CO., LTD.

**400-8261526**

地址:浙江省平阳县郑楼标准厂房基地创业路1号  
电话: 0086-577-63598888  
传真: 0086-577-63083555

E-mail: jbprint@cn-jinbao.com

Add: No.1 Zhenglou Standard Workshop  
Ind.Zone, Pingyang, Zhejiang, China  
Tel: 0086-577-63081555 Fax: 0086-577-63083555

Http: //www.cn-jinbao.com

**hpm**

服务热线:

**400-8085 666**

E-mail: huayue@chinahuayue.com



裁切生产线  
CUTTING SYSTEM



翻转机  
Pile Turner

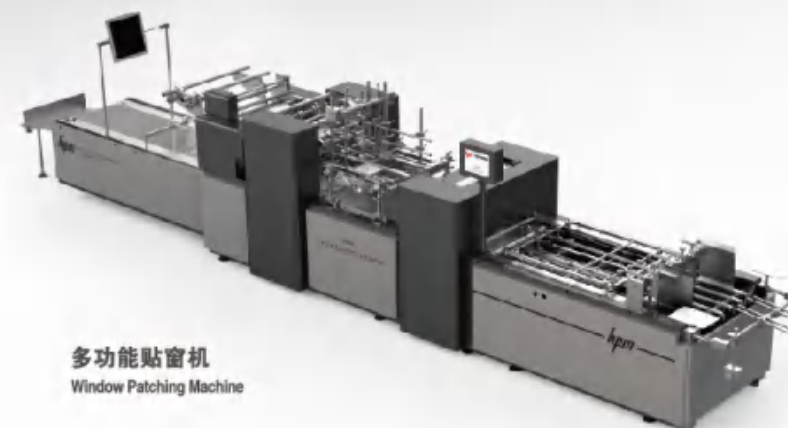

多功能贴窗机  
Window Patching Machine



www.chinahuayue.com

**浙江华岳包装机械有限公司**  
HUAYUE PACKING MACHINERY CO.,LTD

地址 - 中国浙江省瑞安市经济开发区毓蒙路2号  
内销电话 - 0577-65609508 65609972  
外销电话 - 0577-65609528  
传真 - 0577-65609976 65609528

Add - No.2,Yumeng Road of Ruian Economic  
Development Zone,Zhejiang 325200,China  
Sales Department - 0086-577-65609528  
Fax No. - 0086-577-65609528 65609976