

TACHO-P

2024

TACHOPLUS

(타코플러스)

Company introduction

Founded in 1993, **TACHOPLUS** is a company that manufactures and sells post-printing processing machines such as bookbinding machines, wrinkle origami machines, paper extractors, and paper cutting machines. It exports to Korea as well as Europe, the United States, and Asia. All products are made with the highest quality and performance in accordance with CE, ISO 9001, ISO 14001, and ROSE regulations.

회사 소개

타코플러스는 1993년에 설립하여 제본기, 주름 접지기, 종이 추림기, 종이재단기 등 인쇄 후 가공 기계를 제조 판매하는 회사이며, 국내는 물론 유럽 및 미국, 아시아 등 세계 각국으로 수출하고 있으며 모든 제품은 CE(유럽안전규칙), ISO 9001(품질 경영시스템), ISO 14001(환경 경영시스템), ROSE 규정에 따라 최고의 품질과 성능을 가진 제품을 만들고 있습니다.

KOREA FACTORY(DAEGU)



CHINA FACTORY(QINGDAO)



PRODUCT LIST

BINDING MACHINE

- TC - 5700AN PAGE 04
- TC - 5700AC PAGE 05
- TC - 5700C PAGE 06
- TC - 5500SA , SAL PAGE 07
- PUR** • TC - 5500 (A4, A3) PAGE 08
- TC - 5500S, SM, SMS PAGE 09
- TC - 5500C PAGE 10

CUTTING MACHINE

- TC-490,530 PAGE 11

PAPER JOGGER

- TC - 3000 PAGE 12

CREASING MACHINE

- TC6012H/M PAGE 13

PAPER PUNCHING MACHINE

- TC-2000 PAGE 14

PAPER COMPRESS MACHINE

- TC-250 (300, 350) PAGE 15

TC-5700AN

ISO 9001, ISO 14001, CE, ROCE



SPECIFICATION

Book Binding Size	제본규격	310X220mm	Display	디스플레이	Touch Screen(7inch)
Cover Size	표지규격	315X540mm	Power Consumption	소비전력	5.0Kw
Book Thickness	제본두께	2~50mm	Voltage/Frequency	전원	AC220-240V/50-60hz
Cover Thickness	표지두께	100-302gsm	Machine Dimension	제품크기	1930(L)X1250(W)X1220(H)mm
Binding Speed	제본속도	380Cycle/hour	Machine Weight	중량	490kg
Cutting Method	커팅방식	Milling +Scraping	Cover Crease	표지접지	O
Side Glue	옆면풀칠	Side Glue Application	Cover Feed Method	급지방식	Suction Method
Warm-up Time	워밍업	45-50/min			

TC-5700AC

ISO 9001, ISO 14001, CE, ROCE



SPECIFICATION

Book Binding Size	제본규격	310X220mm	Display	디스플레이	Touch Screen(10inch)
Cover Size	표지규격	315X540mm	Power Consumption	소비전력	5.0Kw
Book Thickness	제본두께	2~50mm	Voltage/Frequency	전원	AC220~240V/50~60hz
Cover Thickness	표지두께	100~302gsm	Machine Dimension	제품크기	1690(L)X1330(W)X1220(H)mm
Binding Speed	제본속도	400Cycle/hour	Machine Weight	중량	480kg
Cutting Method	커팅방식	Milling +Scraping	Cover Crease	표지접지	O
Side Glue	옆면풀칠	Side Glue Application	Cover Feed Method	급지방식	Suction Method
Warm-up Time	워밍업	45~50/min			

TC-5700C

ISO 9001, ISO 14001, CE, ROCE



SPECIFICATION

Book Binding Size	제본규격	310X220mm	Warm-up Time	워밍업	45-50/min
Book Cover Size	표지규격	315X540mm	Power Consumption	소비전력	4.0Kw
Book Thickness	제본두께	2-50mm	Voltage/Frequency	전원	AC220-240V/50-60hz
Cover Thickness	표지두께	100-302gsm	Machine Dimension	제품크기	1840(L)X1040(W)X1200(H)mm
Binding Speed	제본속도	300Cycle/hour	Machine Weight	중량	450Kg
Cutting	커팅방식	Milling +Scraping	Cover Crease	표지접지	O
Side Glue	옆면풀칠	Side Glue Application	Cover Feed Method	급지방식	Friction Method
Display	디스플레이	LCD			

TC-5500SA, SAL

ISO 9001, ISO 14001, CE, ROCE



***TC-5500SAL**
Launched in 2025
(2025년 출시)

SPECIFICATION

	TC-5500SA	5500SAL	5500SA	5500SAL
Book Binding Size	제본규격	310X220mm		
Book Cover Size	표지규격	315X500mm		
Book Thickness	제본두께	2~50mm		
Cover Thickness	표지두께	100~302gsm		
Binding Speed	제본속도	380Cycle/hour		
Cutting Method	커팅방식	Milling +Scraping		
Display	디스플레이	LCD Touch Screen(7inch)		
Side Glue	옆면풀칠	Side Glue Application		
		Warm-up Time	워밍업	45~50/min
		Power consumption	소비전력	3.0Kw
		Voltage/Frequency	전원	AC220~240V/50~60hz
		Machine Dimension	제품크기	1510(L)X1100(W)X1080(H)mm
		Machine Weight	중량	450Kg
		Cover Crease	표지접지	X
		Cover Feed Method	급지방식	○ Suction Method

TC-5500PUR

ISO 9001, ISO 14001, CE, ROCE



SPECIFICATION

TC-5500PUR

Book Binding Size	제본규격	320X220,
Cover Size	표지규격	330X540,
Book Thickness	제본두께	2~50mm
Binding Speed	제본속도	200Cycle/hour
Cutting Method	커팅방식	Milling+Scraping
Side Glue	옆면풀칠	Side Glue Application
Glue Tank	풀통	Open Type

TC-5500PUR

Warm-up Time	워밍업	40-45/min
Display	디스플레이	LCD / Touch Screen(7inch)
Power consumption	소비전력	2.5Kw,
Voltage /Frequency	전원	AC220-240V/50-60hz
Dimension	제품크기	1540(L)X650(W)X1120(H)mm
Machine Weight	중량	290Kg

TC-5500S, SM, SMS

ISO 9001, ISO 14001, CE, ROCE



SPECIFICATION

		TC-5500S	SM	SMS
Book Binding Size	제본규격	320X220mm		
Cover Size	표지규격	330X540mm		
Book Thickness	제본두께	2~50mm(70mm)		
Binding Speed	제본속도	350Cycle/hour		
Display	디스플레이	LCD / Touch Screen(7inch)(Option)		
Side Glue	옆면풀칠	Side Glue Application		
	Cutting Method	Scraping,	Scraping+Milling,	Scraping+Milling
	Warm-up Time	45~50/min		
	Power Consumption	2.0Kw,	2.6Kw,	3.4Kw
	Voltage/Frequency	AC220~240V/50~60hz		
	Machine Dimension	1480(L)X650(W)X1070(H)		
	Machine Weight	350Kg,	360Kg,	370Kg

TC-5500C (A3)

ISO 9001, ISO 14001, CE, ROCE



SPECIFICATION

Book Binding Size	제본규격	420X220mm	Display	디스플레이	LCD / Touch Screen(7inch)
Cover Size	표지규격	430X540mm	Warm-up Time	워밍업	40-50/min
Book Thickness	제본두께	2~50mm	Power Consumption	소비전력	2.8Kw
Binding Speed	제본속도	350Cycle/hour	Voltage/Frequency	전원	AC 220-240V/50-60hz
Cutting Method	커팅방식	Scraping+Milling	Machine Dimension	제품크기	1600(L)X550(W)X1050(H)mm
Side Glue	옆면풀칠	Side Glue Application	Machine Weight	중량	300Kg

TC-490, 530

ISO 9001, ISO 14001, CE, ROCE



SPECIFICATION

TC-490 TC-530

Max. Cut Size	최 대 크 기	490,	530mm
Min. Cut Size	최 소 크 기	30mm	
Cut Thickness	재 단 높 이	80,	100mm
Cut Accuracy	재 단 정 밀 도	±0.2mm	
Cut Style	재 단 방 식	Hydraulic Pressure	
Display	디 스플 레 이	Touch Screen(7inch)	
Power Supply	전 원	AC220-240V/60hz	
Power Consumption	소 비 전 력	1.5Kw,	1.8Kw
Dimension(490)	제 품 크 기	875(L)X1183(W)X1414(H)mm	
Dimension(530)	제 품 크 기	920(L)X1270(W)X1460(H)mm	
Machine Weight	중 량	300kg,	350kg

TC-520

ISO 9001, ISO 14001, CE, ROCE

* NEW MODEL



TOUCH SCREEN

SPECIFICATION

Max. Cut Size	최 대 크 기	520mm
Min. Cut Size	최 소 크 기	30mm
Cut Thickness	재 단 높 이	100mm
Cut Accuracy	재 단 정밀도	±0.2mm
Cut Style	재 단 방 식	Servo Motor Gear Method
Display	디 스플 레 이	Touch Screen(7inch)
Power Supply	전 원	AC220-240V/60hz
Dimension	제 품 크 기	1170(L)X930(W)X1420(H)mm
Machine Weight	중 량	330kg

TC-3000

ISO 9001, ISO 14001, CE, ROCE



SPECIFICATION

Paper Size	제 본 규 격	128mm~483mm
Frequency	소 비 전 력	1.5kw
Voltage	전 원	AC220~240V/50~60hz
Dimension	제 품 크 기	480(L)X410(W)X1190(H)mm
Weight	중 량	31kg.

TC-6012H, M

ISO 9001, ISO 14001, CE, ROCE



SPECIFICATION

TC-6012H 6012M

Paper Size	용 지 크 기	340X900mm	
Paper Thickness (Creasing)	용 지 두 께	80~350,	100~350g/mm
Paper Thickness (Perforating)	용 지 두 께	80~300,	100~200g/mm
Paper Loading	용 지 적 재	100mm	
Accuracy	정 밀 도	±0.3mm	
Working Speed	속 도	3500,	2400 pages/hour
Creasing quantity on one paper	접 지 횟 수	0 to 32 times	
Feeding Type	급 지 방 식	Suction Feeding	Manual
Voltage	전 원	AC220~240V/50~60hz	
Power	소 비 전 력	300w,	150w
Machine Weight	중 량	78kg,	42kg
Machine Dimension(6012H)	제 품 크 기	800(w)x600(l)x1200(h)mm	
Machine Dimension(6012M)	제 품 크 기	600(w)x600(l)x580(h)mm	

TC-2000

ISO 9001, ISO 14001, CE, ROCE

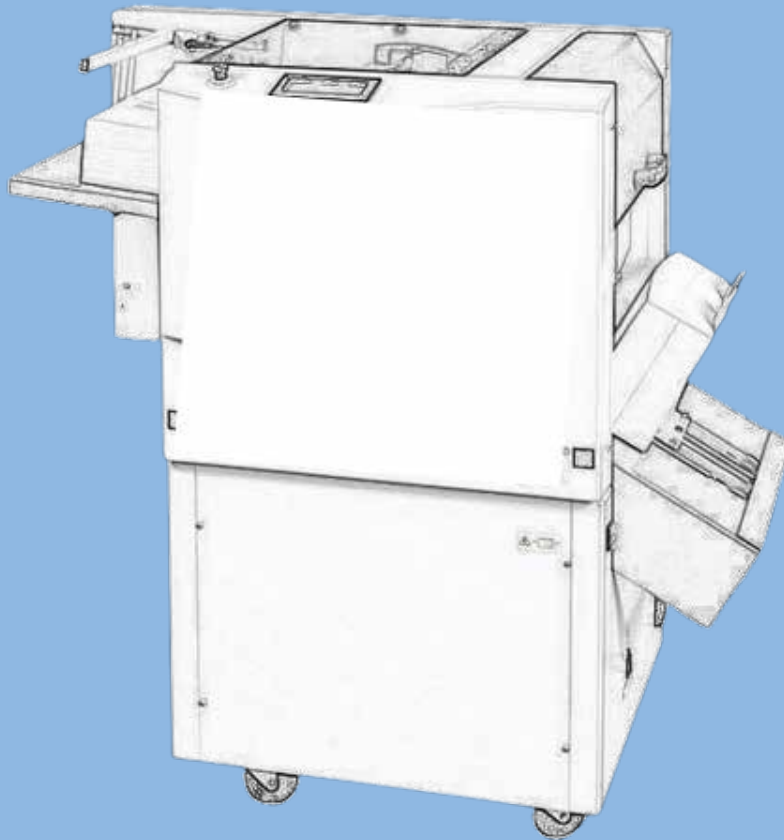

***Launched in 2025
(2025년 출시)**

SPECIFICATION

Book Binding Max Size	최 대 크 기	304X355mm
Book Binding Min Size	최 소 크 기	140X140mm
Load Capacity	적 재 용 량	280mm
Paper Thickness	용 지 두 께	80~230gms
Workflow	작 업 속 도	4200 pages/hr(A4)
Error Indication	에 러 표 시	Paper Jam, No Paper, Outlet Full Load
Voltage/Frequency/	전 원	AC220-240V/50~60hz
Power Consumption	소 비 전 력	0.55Kw
Machine Dimension	제 품 크 기	1250(L)X720(W)X1250(H)mm
Machine Weight	중 량	280kg

TC -250(300,350)

ISO 9001, ISO 14001, CE, ROCE

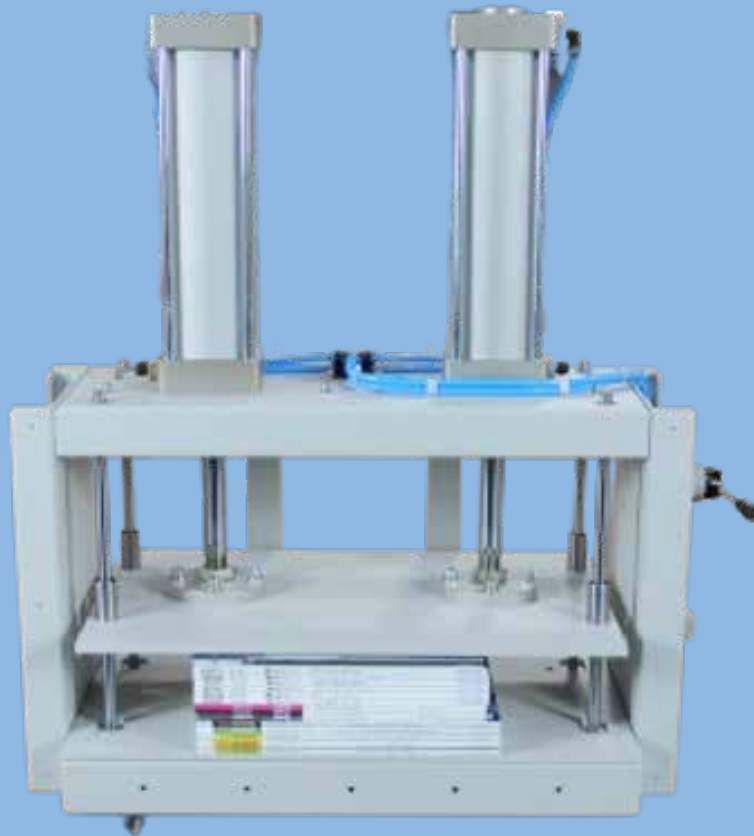

SPECIFICATION

Option

Paper Size	450X360mm	
Load Height	10~250mm	(300/350)
Operatopm	Pneumatic Method	
Dimensions	700(L)x390(W)x800(H)mm	
Weight	90kg	

Headquarters(KOREA)

TACHO-P

TACHOPLUS
(타코플러스)

<http://www.tacho-p.com>

103, Geomdan-Techpart, 26, Geomdangongdan-ro,
Buk-gu, Daegu, Korea 41514
Tel : 053-355-1926(rep) / Fax : 053-355-1921
E-mail : tachop1@hanmail.net